

Contents

Safety, Warnings and Cautions	3	Normal Operating Instructions	30
Safety, Warnings continued	4	Activating and Deactivating the Auto-Close and Lock Feature	31
FCC Guideline	5	Power Failure - Manual Lock Operation	32
Required Tools	6	Replacement Parts and Accessories	33
Hardware Kit Contents	7	How to Change Batteries	34
Step 1 Unpacking & Layout	8	Warranty Limitations and Guidelines	35
Step 2 Preparing Door Operator	9	Troubleshooting	36
WARNING	10	Troubleshooting Remotes	37
Step 3 Preparing Door	11	Troubleshooting Lock Control Box	38
Step 4 Marking Door For Correct Lock-Head Position	12	Troubleshooting Lock Head	39
Step 5 Mounting The First Lock-Head	13	Troubleshooting Garage Door Operator Opening	40
Step 6 Mounting The Second Lock-Head	14	Troubleshooting garage Door Operator Closing	41
Step 7 Fastening Wire Cable to Door	15	Guide for Unlearning your Operator Remotes.	42
Step 8 Making the Receiver Holes in the Track	16	Lock Installation on garage doors with “Wayne Dalton” opnrs.	43
Step 9 Mounting Plastic Bracket to Track	17	Mounting New Wall Switch	44
Step 10 Routing Wire	18		
Step 11 Suspending Wire Harness From Header to Operator	19		
Step 12 Supporting String	19		
Step 13 Attaching Wire to String	19		
Step 14 Mounting Electrical Control Box	20		
Step 15 Making Wiring Connections	20		
Wiring Diagram	21		
Step 16 Mounting Magnetic Door Switch	22		
Step 17 Checking Clearances	22		
Step 18 Installing Red L. E. D.	23		
Step 19 Install Through Door Panel	24		
Step 20 Powering Up	25		
Step 21 Learning Remotes	25		
Step 22 Latch Door to Rail	25		
Step 23 Operational Check.	25		
This Section is For One Piece Doors ONLY	26		
How to Mount Lock-Head (A) and (B) On a One Piece Door	27		
Metal Wire Harness Bracket for One Piece Doors	28		
One Piece Door Magnetic Switch Installation	29		

Safety, Warnings and Cautions

IMPORTANT INSTALLATION INSTRUCTION

! WARNINGS !

To reduce the risk of severe injury or death:

READ AND FOLLOW ALL INSTRUCTIONS AND WARNINGS.

1. Before servicing any garage door opener the garage door lock must be manually unlocked and disabled.
2. Install garage door lock only on properly balanced and lubricated garage door. An improperly balanced door may not reverse when required and could result in SEVERE INJURY or DEATH.
3. All repairs if needed, to cables, spring assemblies and other hardware MUST be made by a trained door systems technician BEFORE installing the lock.
4. NEVER connect garage door lock to power source until instructed to do so.
5. NEVER wear watches, rings or loose clothing while installing or servicing lock or operator. They could be caught in garage door, lock, or operator mechanisms.
6. To prevent possible SERIOUS INJURY or DEATH: ALWAYS call a trained door systems technician if garage door binds, sticks, or is out of balance. An unbalanced garage door may not reverse when required.
7. ONLY operate garage door lock and operator at 110VAC 60HZ to avoid malfunction and damage.
8. Without a properly working safety reversal system, persons (particularly small children) could be SERIOUSLY INJURED or KILLED by a closing garage door.

Safety, Warnings and Cautions

9. To prevent INJURY from pinching, Keep hands, and fingers away from the joints while installing and testing the lock system on the garage door.

10. Review the SAFETY GUIDE in the operator owners manual

While installing the GARAGE DOOR LOCK use common sense. If you are unclear on the instructions or if you do not feel comfortable installing the lock system contact a qualified service technician.

Control box light bulb.

Caution: Use 60 watt max. incandescent bulb only.

FCC Guideline

Changes or modifications not expressly approved by Elocksys, Inc. could void the user's authority to operate the equipment.

This product has been tested and complies with the specifications for a Class B digital device, pursuant to Part 15 of the FCC Rules. These limits are designed to provide reasonable protection against harmful interference in a residential installation. This equipment generates, uses, and can radiate radio frequency energy and, if not installed and used according to the instructions, may cause harmful interference to radio communications.

However, there is no guarantee that interference will not occur in a particular installation. If this equipment does cause harmful interference to radio or television reception, which is found by turning the equipment off and on, the user is encouraged to try to correct the interference by one or more of the following measures:

- Reorient or relocate the receiving antenna
- Increase the separation between the equipment or devices
- Connect the equipment to an outlet other than the receiver's
- Consult a dealer or an experienced radio/TV technician for assistance

Required Tools

Drill

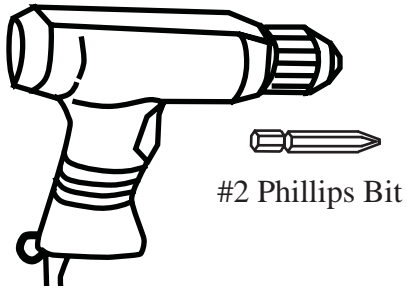

#2 Phillips Bit

5/16 Socket driver

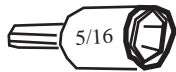

#2 Phillips screw driver



#0 Phillips screw driver



Pencil

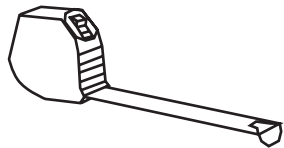

16' Tape Measure



5/16", 3/8"* Drill bits



1/8" Drill bit

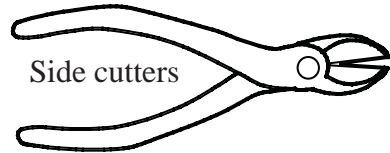

Side cutters

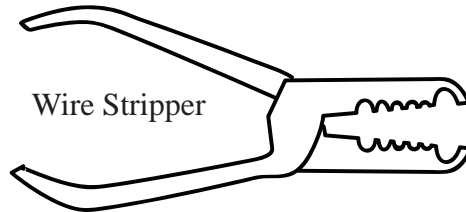

Wire Stripper



7/16" wrench



Medium metal file*



Keyhole Metal Saw*

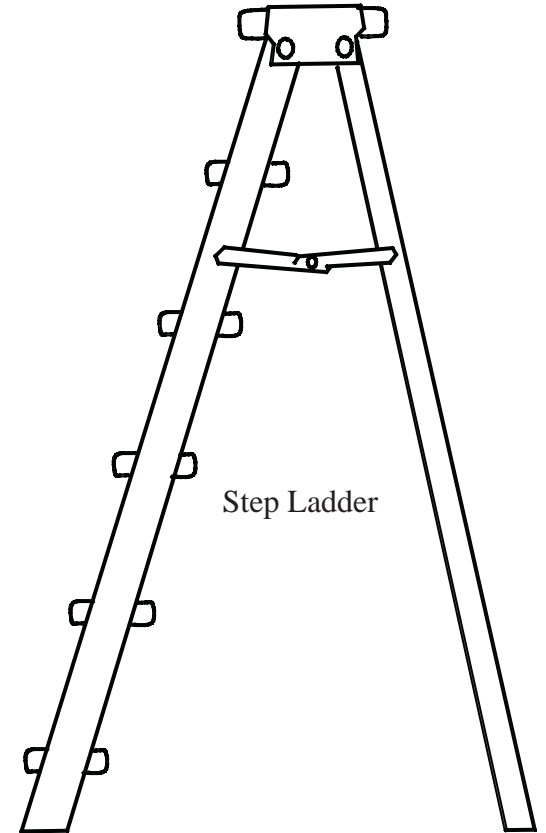

Step Ladder

* Only needed to cut bolt hole.

Hardware Kit Contents

Plastic control wire bracket

One hole strap for wire cable Support

Qty 7



Qty 1

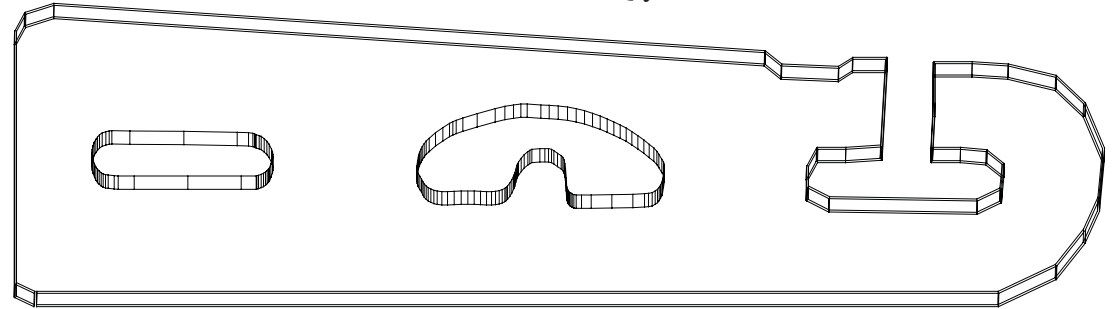

One hole strap for Magnetic Switch

Qty 1

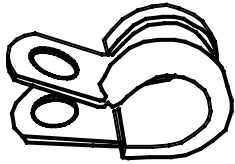

Qty 4

7" Tie Strap

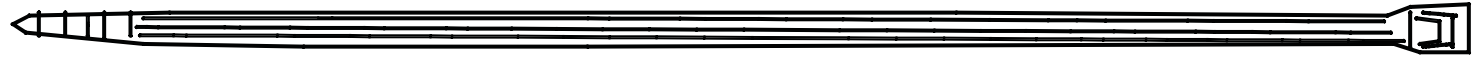

Qty 10

4" Tie Strap



8 X 1 5/8" inch Drywall screw

Qty 5



1" X 1/4" 20 Bolt and flange nuts for Plastic wire bracket

Qty 2

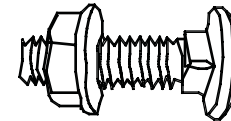

LED Socket

Qty 1

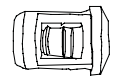

#12 X 3 inch hex head mounting screws

Qty 4



Plastic Magnet and Bracket

Qty 1

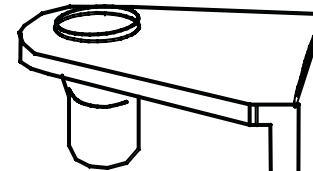

#6 X 3/4 inch pan head-Phillips (use with #5 one hole straps)

Qty 5



Qty length 36"
Bell switch wire

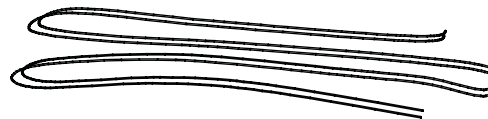

#8 X 2 inch screw hook

Qty 1

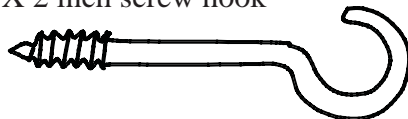

Nylon string

Qty 10 ft



Step 1

Unpacking & Layout

Unpack contents from box taking extreme care not to bend or kink wire cable. Lay lock assembly on floor inside garage with door closed. Place lock head (A) on your left looking at the door from inside, lock head (B) on right.

Stop and double check to see if you have the correct lock kit for your garage door (roll up or one piece), **operator** (random or fixed code) and that **door size matches the lock size**.

This step is also used for one piece door installation.

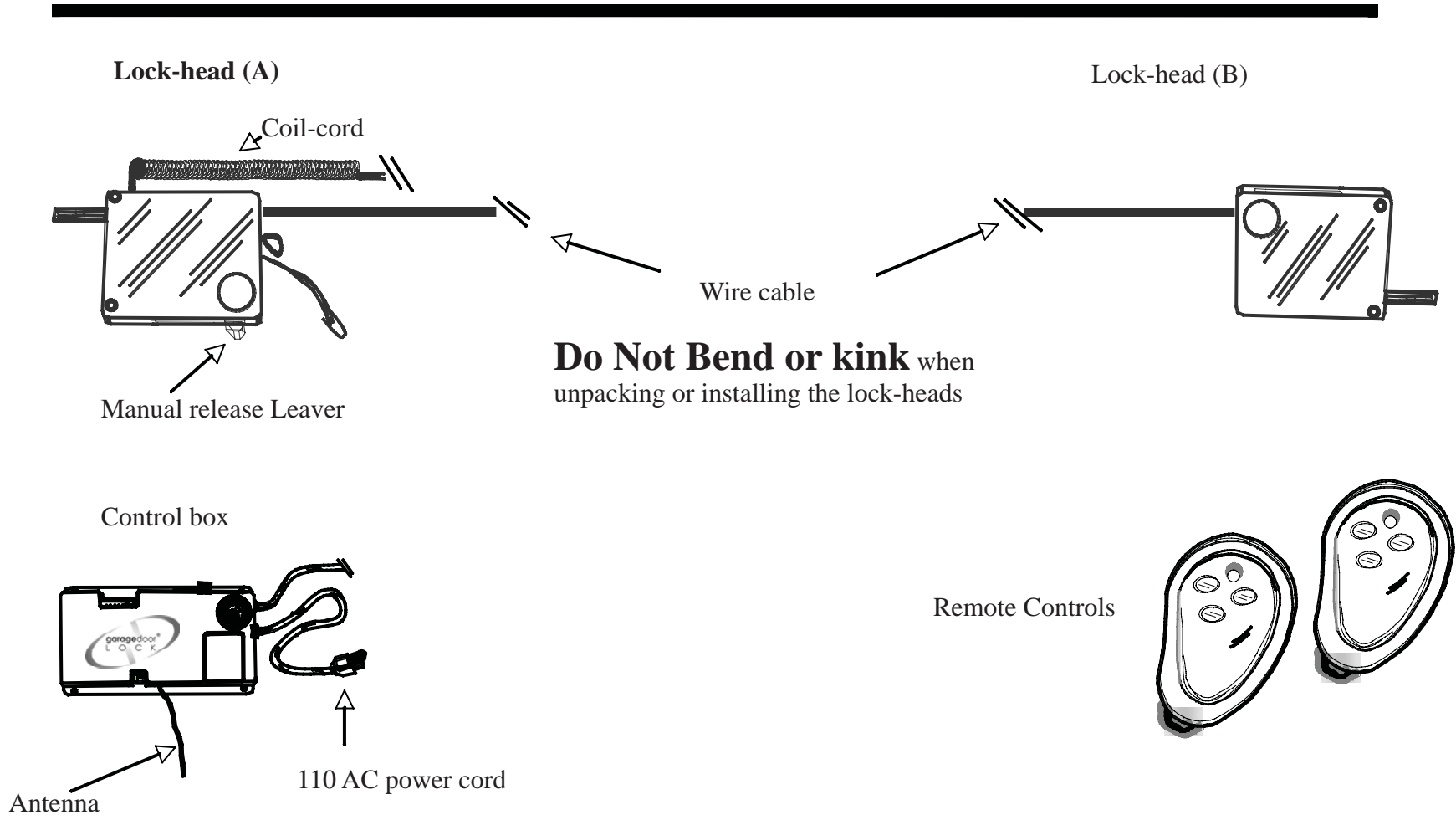

Preparing Door Operator

Caution: DO NOT MISS THIS STEP
Find all remotes to your current door operator!!!

Step 2

DO THIS NOW !!!

FOLLOW THE INSTRUCTIONS BELOW. Failure to follow the instruction or disable the old remotes and keypads will result in a broken door, lock, operator, and may cause bodily injury.

Preparing Door Operator

Random Code: Unlearn all remotes and keypads following the procedures from the manufacturers manual or on the door operator near the learn button. (Refer to **page 42** of this manual for unlearning opener remotes and keypads.)

Fixed Code: (with dip switches) Remove all batteries from existing remotes, key pad and store away. Place these items in the RED bag supplied with kit.

CAUTION: YOU MUST NEVER ATTEMPT TO OPERATE THE GARAGE DOOR OPERATOR WITH YOUR OLD REMOTES OR KEY-PAD AS LONG AS THE LOCK IS INSTALLED ON THE GARAGE DOOR.

Such attempts will jam the lock and door resulting in damage to the door or possibly the door operator. See Warning Sheet.

DO NOT IGNORE OR BYPASS THIS STEP.

WARNING

DO NOT EVER USE THE OLD OPERATOR REMOTES OR KEY-PAD While the lock is installed on the door.

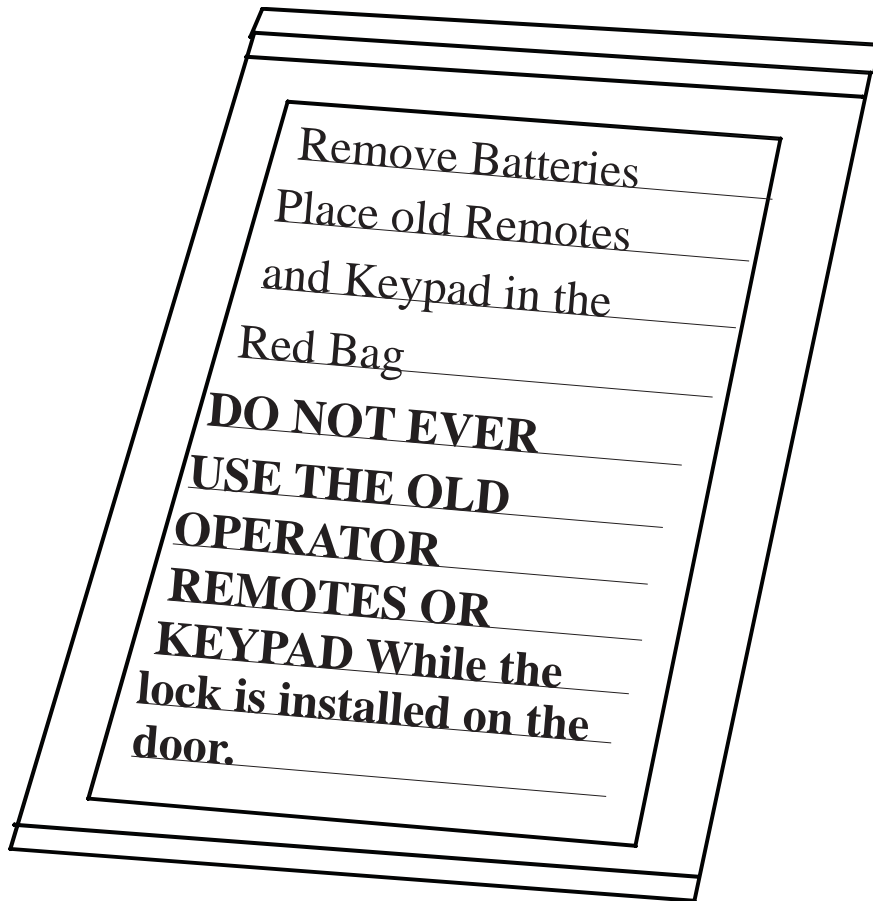

IF THE DOOR OPERATOR DOES NOT ACTIVATE TO OPEN WHEN THE WALL SWITCH, NEW KEYPAD, OR NEW REMOTE BUTTONS ARE PRESSED, **DO NOT ATTEMPT TO USE THE OLD REMOTES, DO NOT ATTEMPT TO BYPASS THE WALL SWITCH OR CROSS CONNECT THE TERMINALS IN AN EFFORT TO TROUBLESHOOT THE OPERATOR**

THE LOCK MUST BE MANUALLY UNLOCKED AND THE OPERATOR RELEASE CORD OR LEVER MUST BE DISENGAGED BEFORE TROUBLESHOOTING STEPS ARE TAKEN

Preparing Door

Unplug garage door operator from 110 AC outlet. Do not pull release rope on operator until instructed to do so.

** Note: For Wayne Dalton I drive and all wireless indoor control wall console models, stop here and follow instruction on pages 43 and 44.

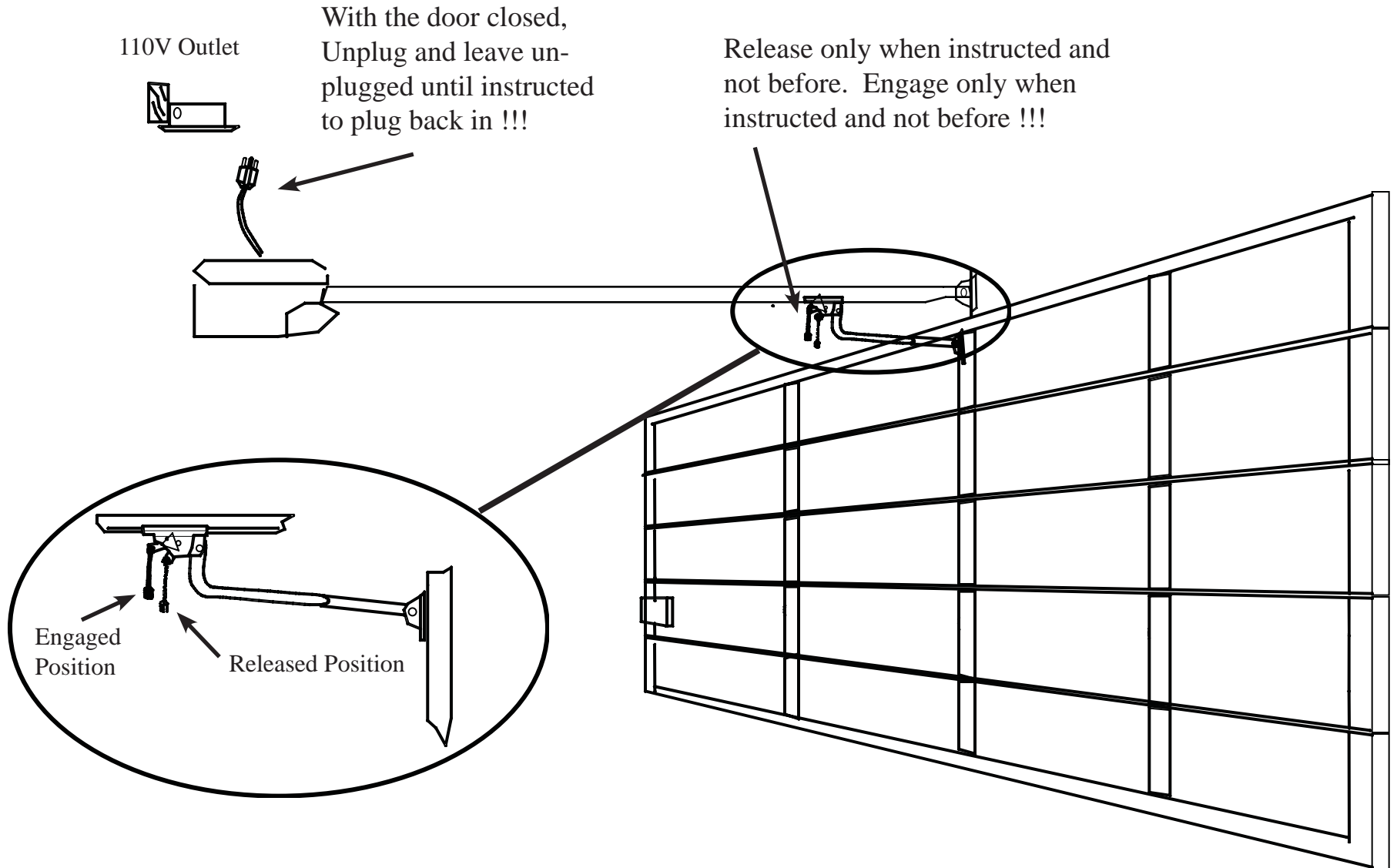

Marking Door For Correct Lock-Head Position

Step 4

Start with the garage door closed completely. To prevent any possibility of stretching the wire cable, **use dimension** given on sheet labeled “**Use This Dimension**”, as a reference for lock-head location. Make marks on door as shown in **figure 1**. **Note:** counting up from the floor, **panel 2** is used for doors with **4 panels**, location (A) and **panel 3** is used for doors with **5 panels**, location (B). **Note:** Location of lock-heads on correct panel is important to **avoid coil-cord overstretching**. You should also find lock receiver holes or knock-outs in these locations on the door track.

Note: Not all tracks have pre-made holes. Tracks without holes will need holes cut out. See **step 5**.

Figure 1

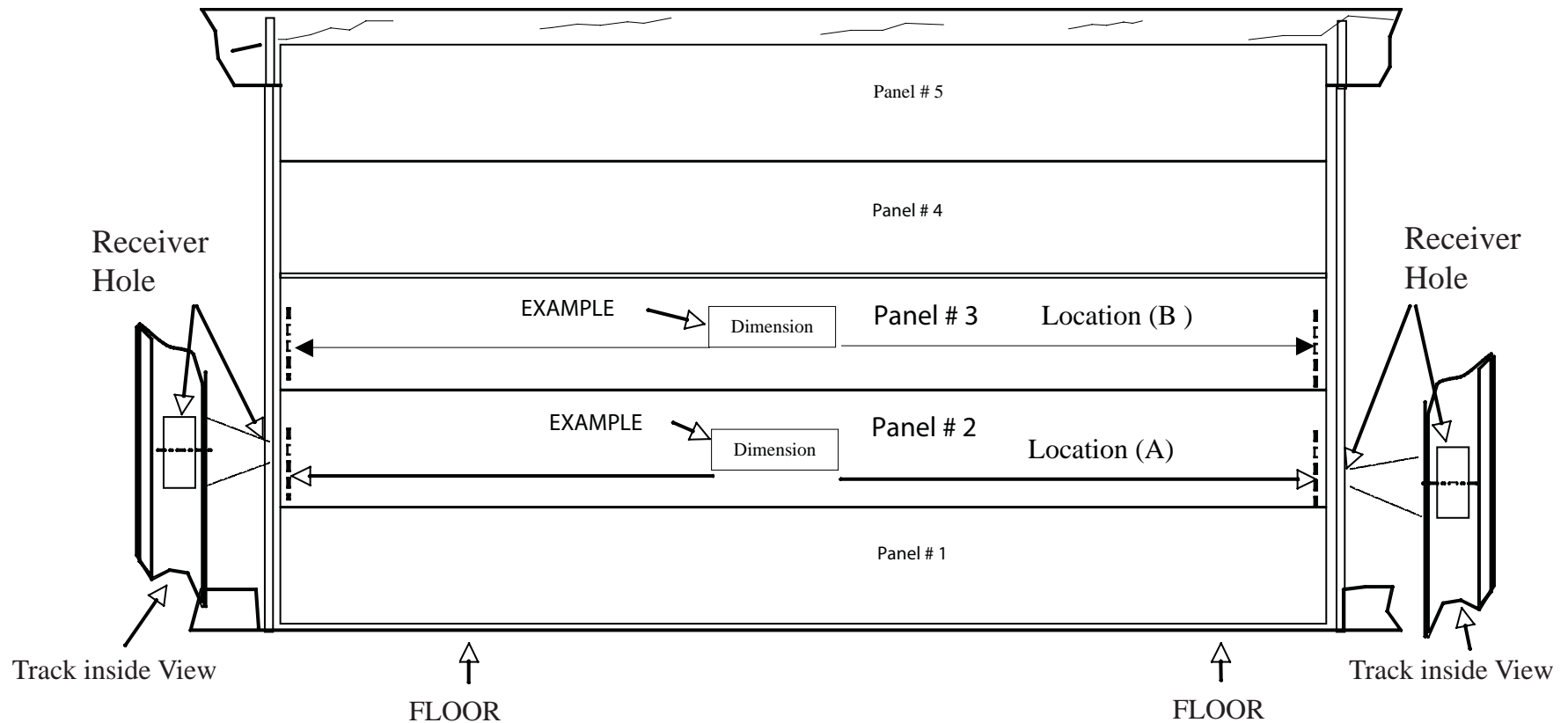

Mounting The First Lock-Head

After determining correct door panel to mount lock as described in step 4, locate any existing lock receiver hole or precut knockouts in the door track. Manually move lock to it's full lock position. Insert dead bolt into receiver hole in track and center it vertically. Make sure lock does not interfere with any hinges or hardware. Now mount lock head A aligning with mark made in step 4 using 3" mount screws. Make sure dead bolt is centered in hole. Manually unlock dead bolts and refer to step 6 to mount lock head B. It may be necessary to cut hole in track for lock head B.

Tracks without cut outs

If hole does not exist, one must be made. After determining correct door panel as described in step 4, pick location on panel which does not interfere with any hardware or hinges. Mount lock head A aligning with mark made in step 4 using 3" mount screws. Refer to step 6 to mount lock head B.

Suggestion: Temporarily secure cable to door using tape while mounting lock head B.

Figure 2 Lock-head (A) alignment on left track

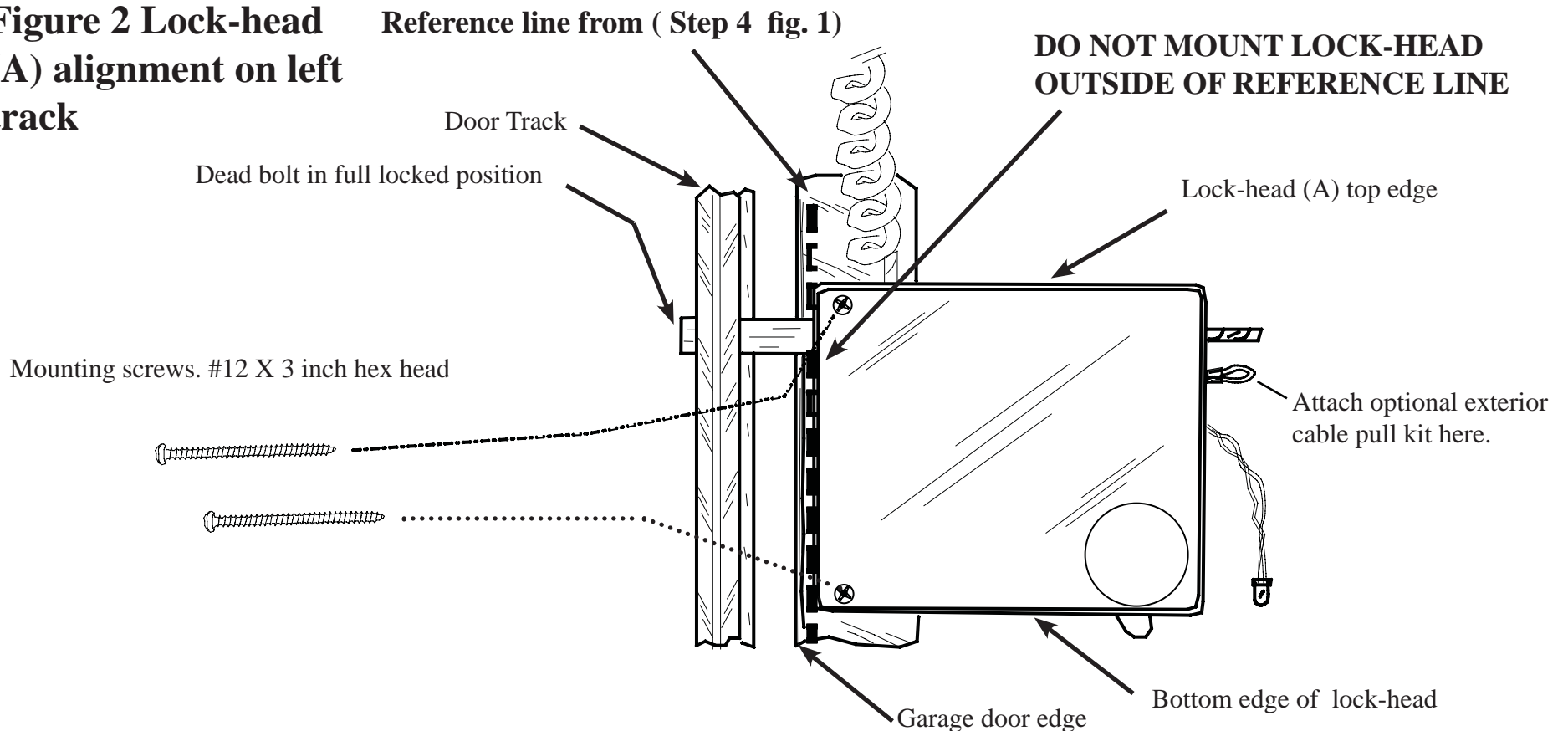

Mounting The Second Lock-Head

Step 6

Measure the distance from floor to bottom edge of the previously mounted lock-head. Use this measurement to set the vertical height of the second lock-head to be mounted. See **figure 4**. Mount the second lock-head, using the reference mark made on the door from step 4 **never letting outer edge of lock head go past mark**. See **figure 3**. Manually extend the dead bolt until contact with track is made. From center of dead bolt measure vertically 1-1/8" up, then down, make cut marks. From center of dead bolt measure horizontally to one side 5/8" and then to the other side, make cut marks.

Figure 3 Lock-head (B) alignment on right track

Position outer edge of lock-head at the reference line, drill 1/8 inch pilot holes, insert mounting screws. Tighten the mounting screws.

DO NOT MOUNT LOCK -HEAD OUTSIDE OF REFERENCE LINE

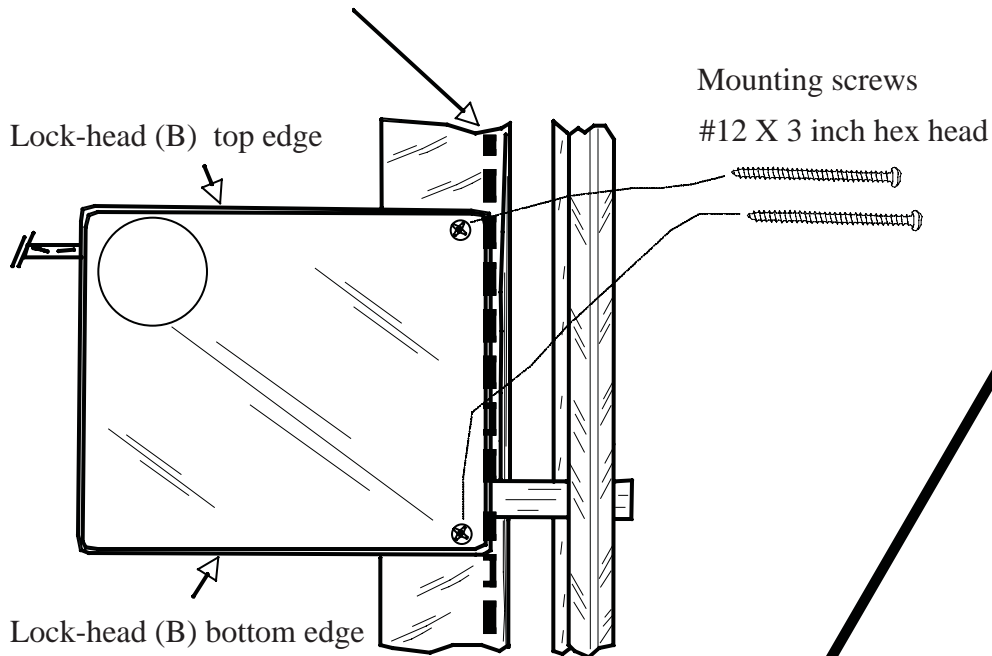
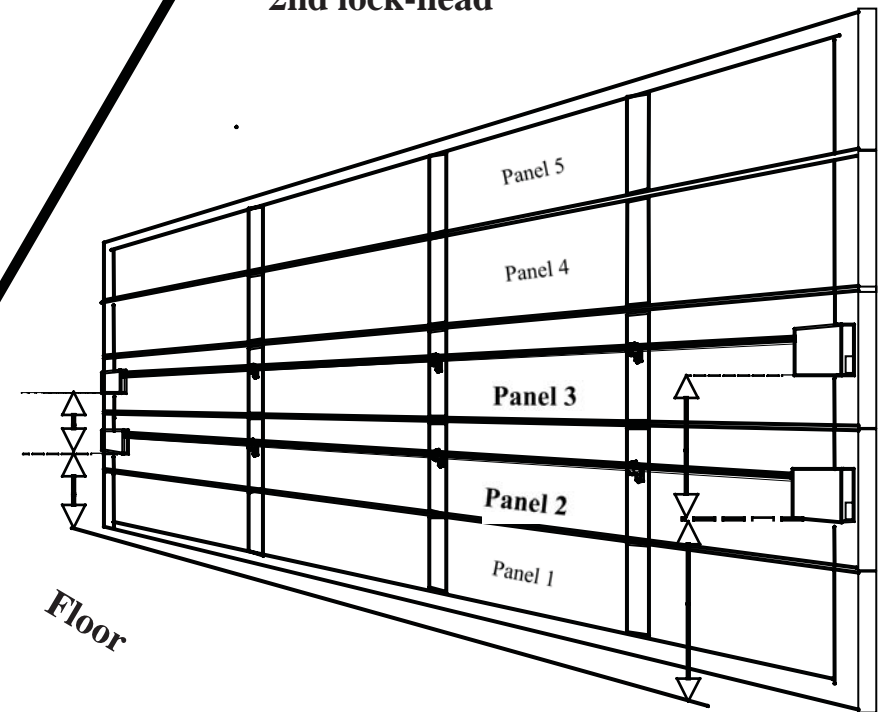

Figure 4 Alignment for mounting 2nd lock-head



Fastening Wire Cable to Door

Step 7

While keeping cable straight and level, use plastic one hole straps and screws supplied with the kit to fasten wire cable to inside of door. See **figure 5**.

This step is also used for one piece door installation.

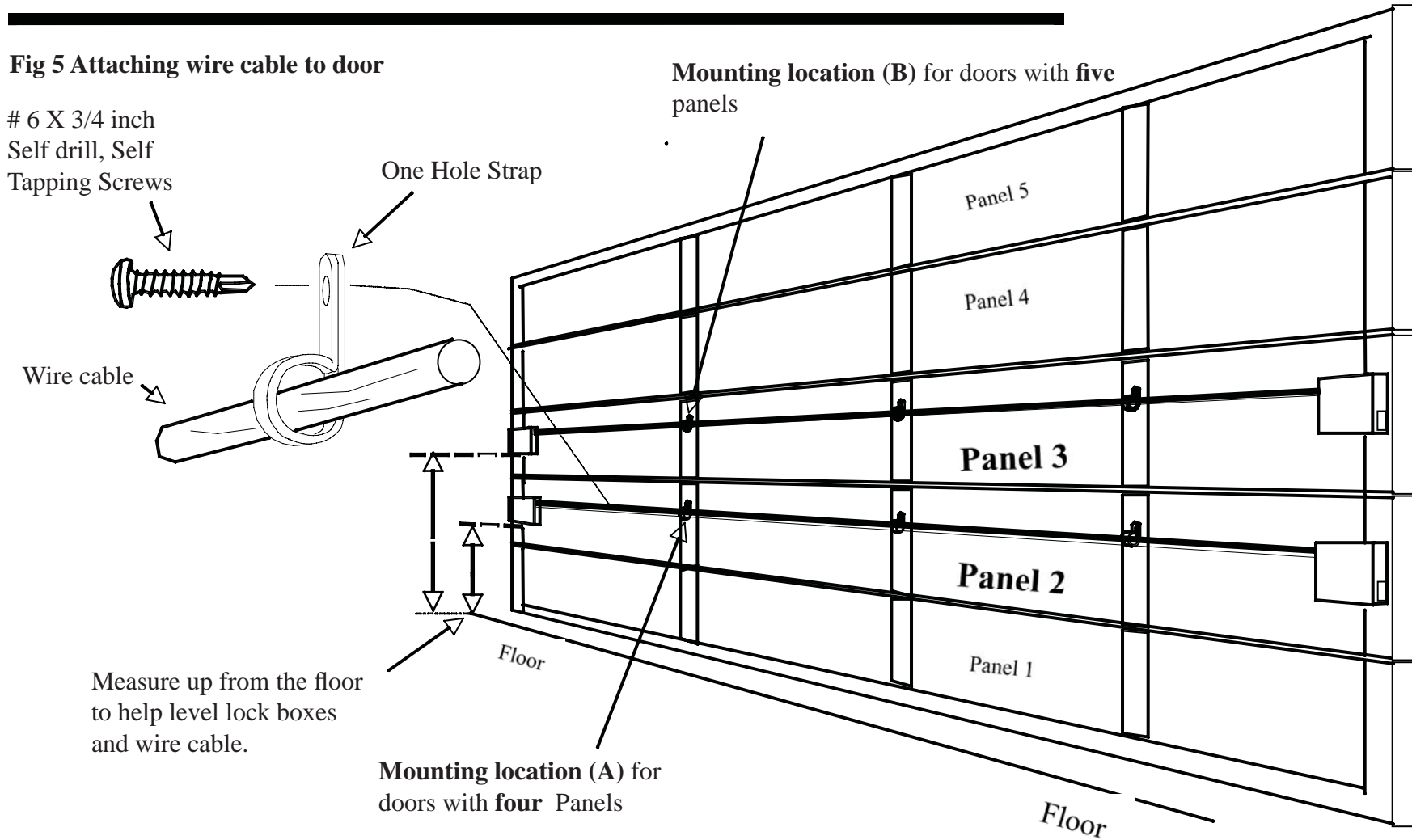

Step 8

Making the Receiver Holes in the Track

Manually retract the dead bolt, pull release rope on operator to disengage door. Lift door manually and make receiver holes using marks made previously in step 5. See figure 3 below for details.

Close door and operate lock manually, look for the dead bolt to extend through the receiver hole. See figure 3. Be sure receiver hole is clean with no jagged edges. Use the file to clean up hole edges.

Figure 3 Lock-head alignment on left track

Ideal dead bolt to receiver alignment and clearance.

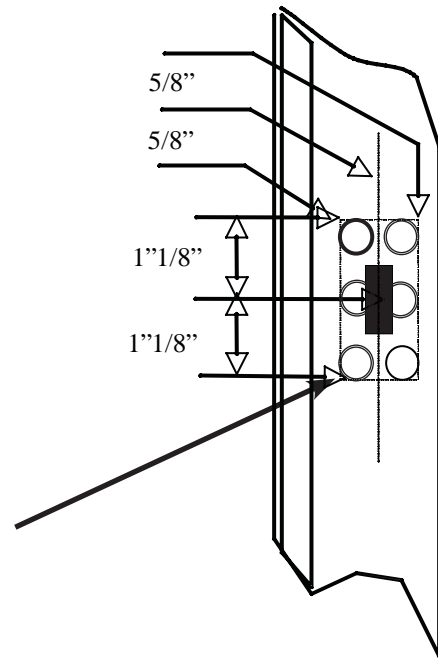

Suggestion for making receiver hole. Drill six - 3/8 inch diameter holes inside of your marks. Then cut between the holes and finish edges with a metal file. Do not leave bent or uneven edges.

Mounting Plastic Bracket to Track

Remove 2 bolts from track near top of door on left track. Mount bracket using nuts and bolts supplied. See **Figure 4**. Stretch and attach wire as shown in **Figure 5**.

Figure 4 Attaching Plastic Wire Bracket to Garage Door Track

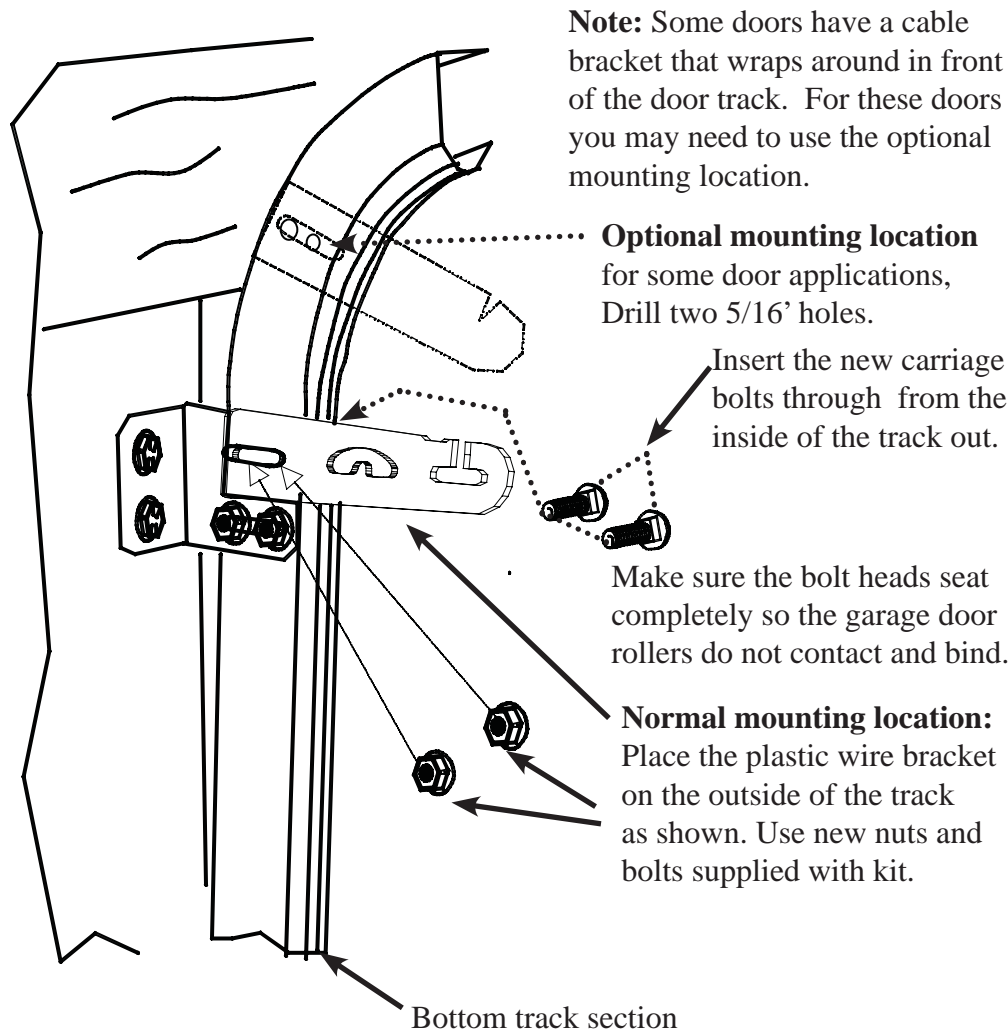
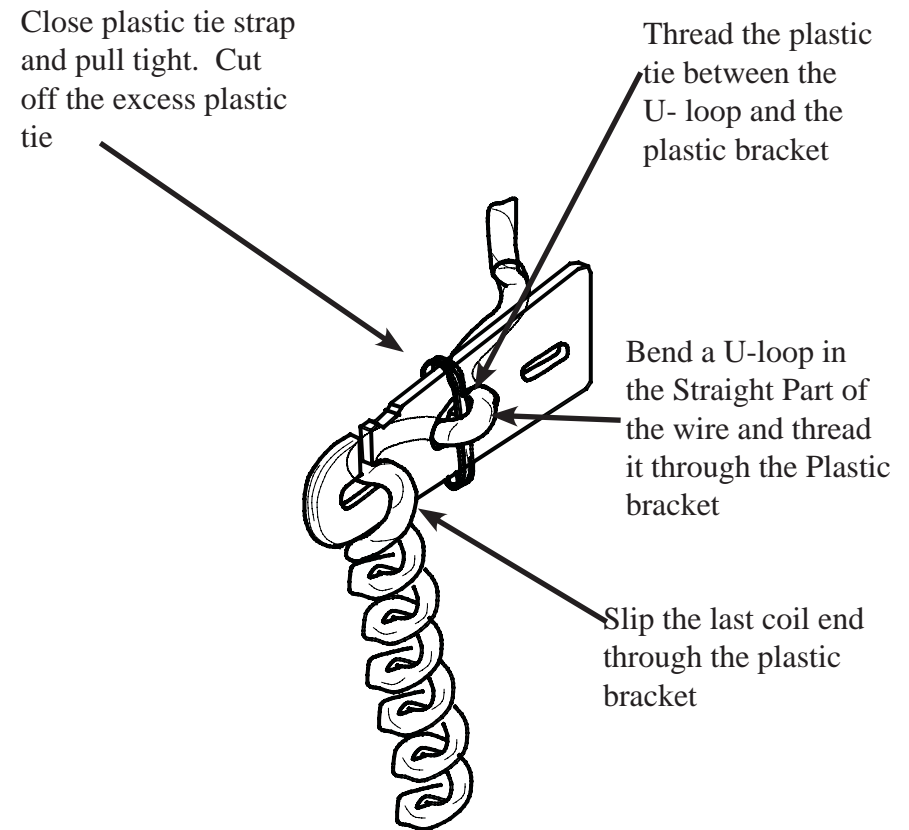

Figure 5 Attaching Wire To Plastic Bracket



Step 10

Routing Wire

Carefully route wire up the wall, around track and drum assembly. Fasten wire to header using four of the plastic one hole straps with 1 5/8" drywall screws supplied with with kit. Follow diagram for wire routing see figure 6.

Figure 6 Routing and attaching wire on the wall

Wrap the sensor wire around a Phillips screw driver to train the wire into a neat coil-cord before attaching the sensor to the header. Do not mount until instructed to do so.

Make sure to clear the drum and hardware but route wire over the shortest possible distance, making sure not to come up short at the control box.

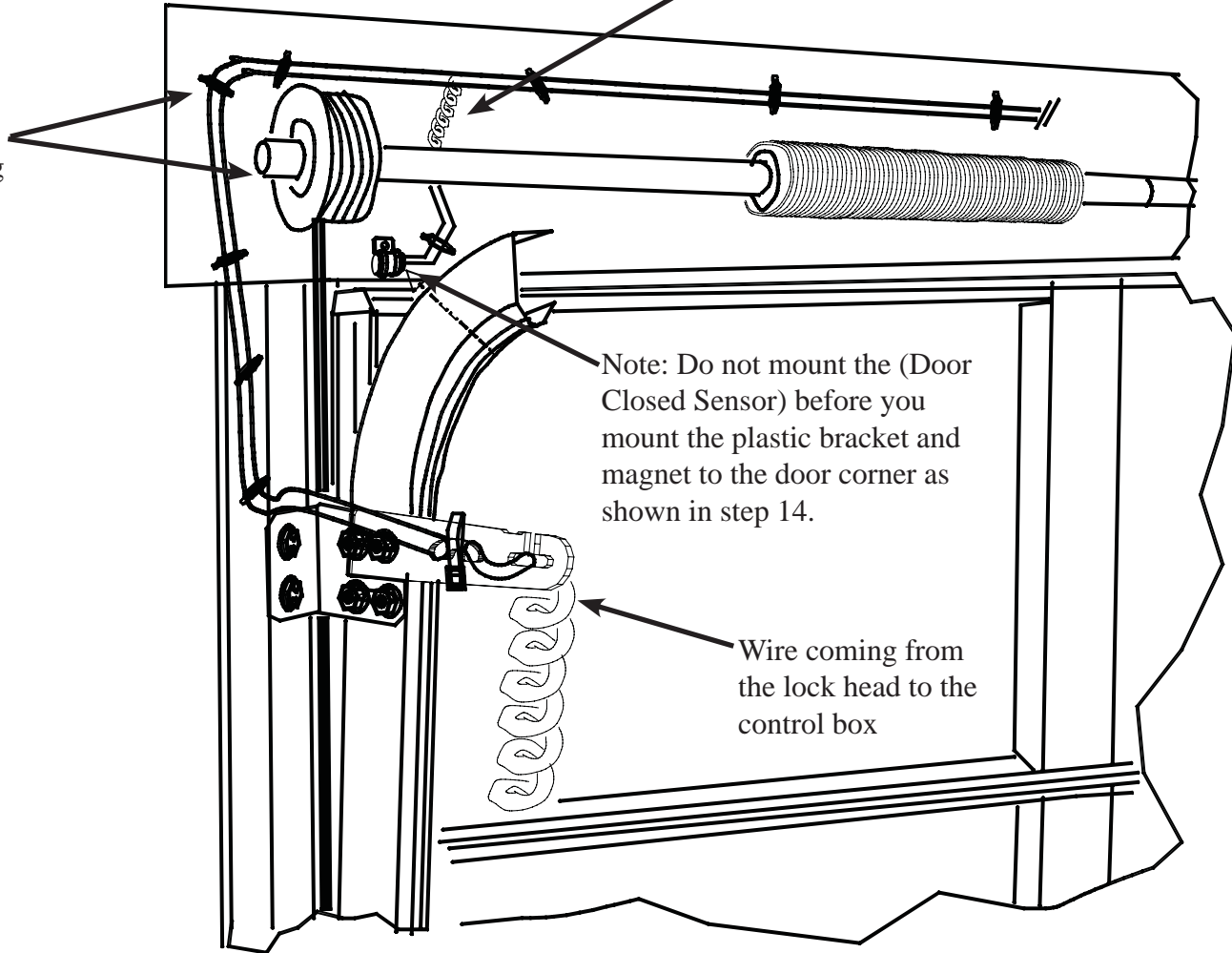

Step 11

Suspending Wire Harness From Header to Operator

Install screw hook into header approximately 6" from operator rail on the right side, facing the header. At height of operator mounting point, see **figure 7**.

Step 12

Support String

Tie one end of string to operator frame. See **figure 7**. Make loop on other end of string approximately 6" short of reaching hook. After tying loop stretch string till tight and place over hook. Make sure string stretches very tight to avoid sagging and contact with the garage door

Step 13

Attaching Wire to String

Attach wire harness to support string by using tie straps supplied in kit see **Figure 7**.

Figure 7 Screw hook and wire tie off locations

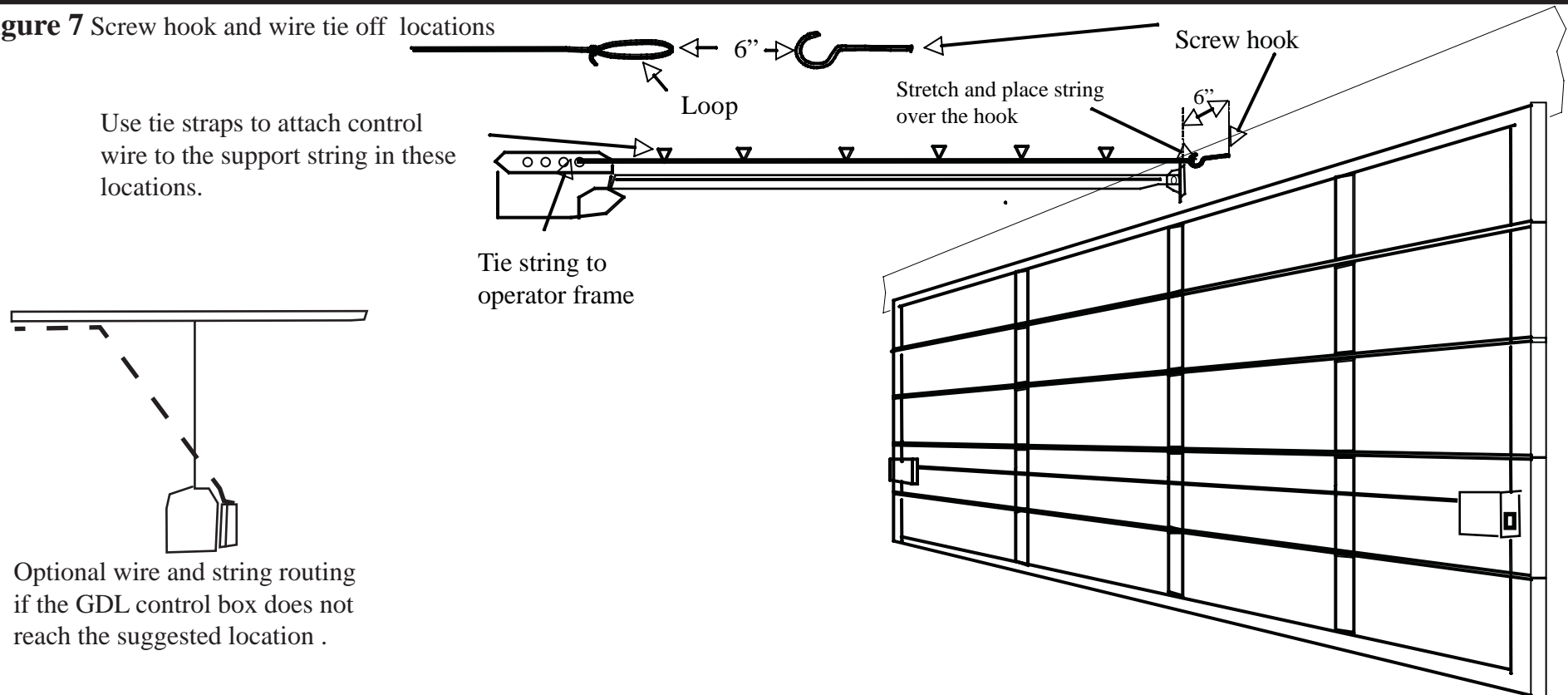

Step 14

Mounting Electrical Control Box

Mount electrical control box by using tie straps see figure 8. Use method best suited for application.

Step 15

Making Wire Connections.

Note: (The **Safety Beam Sensor** wires must stay connected to the operator, do not change terminal position.) Only the bell wires get changed as shown.

Connect bell wire for electrical box see figure 8. Make sure all wiring is clear of any moving parts.

After making connections place the wall sticker labeled “Activating and Deactivating Autoclose and Lock feature”, near wall / bell switch.

Figure 8 Mounting Electrical Control Box and Making Wire Connections.

Mount control box on or next to door operator frame.

Note: Do not lay box on top of operator .

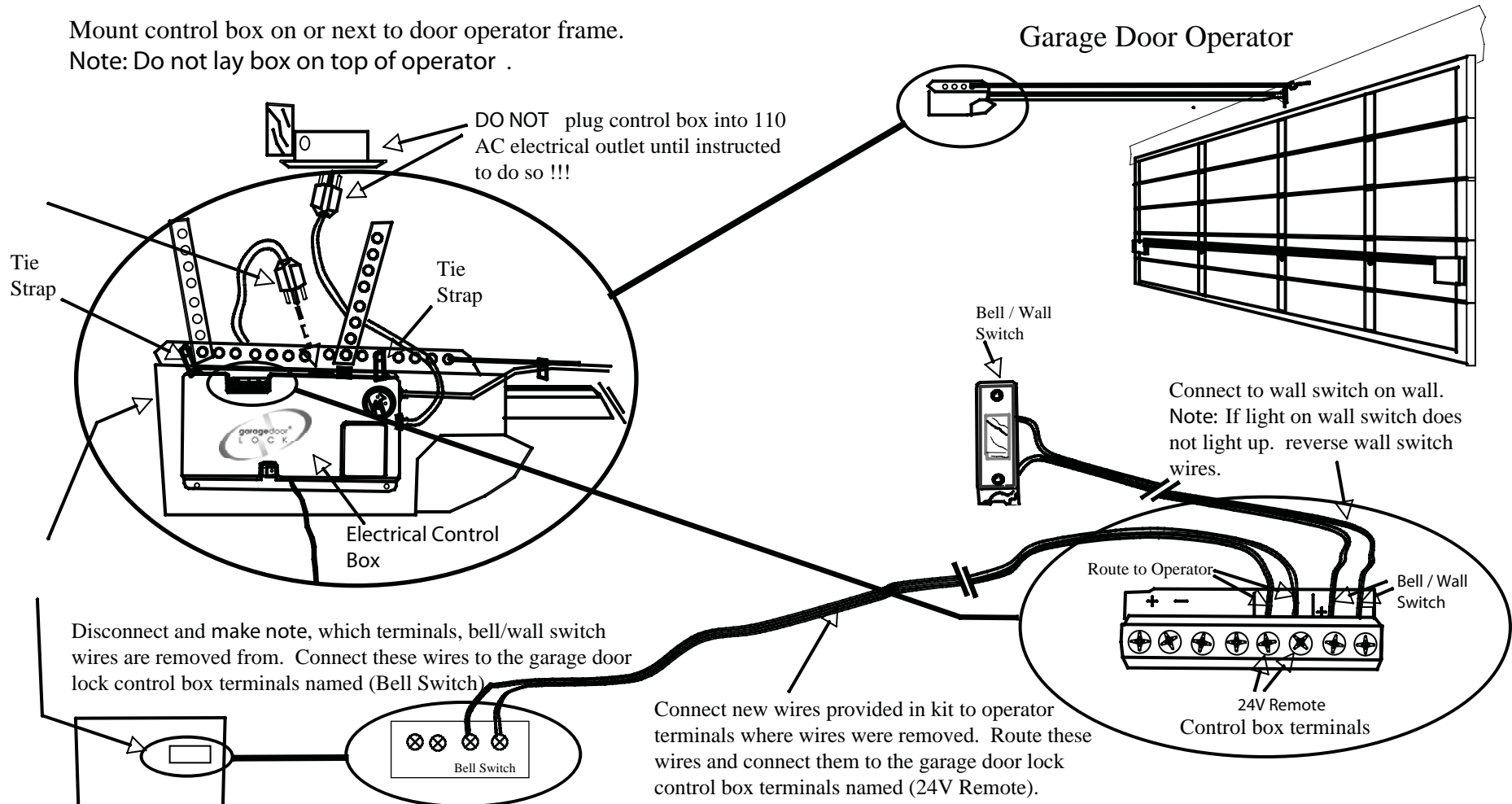

WIRING DIAGRAM FOR CONTROL BOX AND BELL SWITCH

Note: (The **Safety Beam Sensor** wires must stay connected to the operator, do not change terminal position.) Only the bell wires get changed as shown.

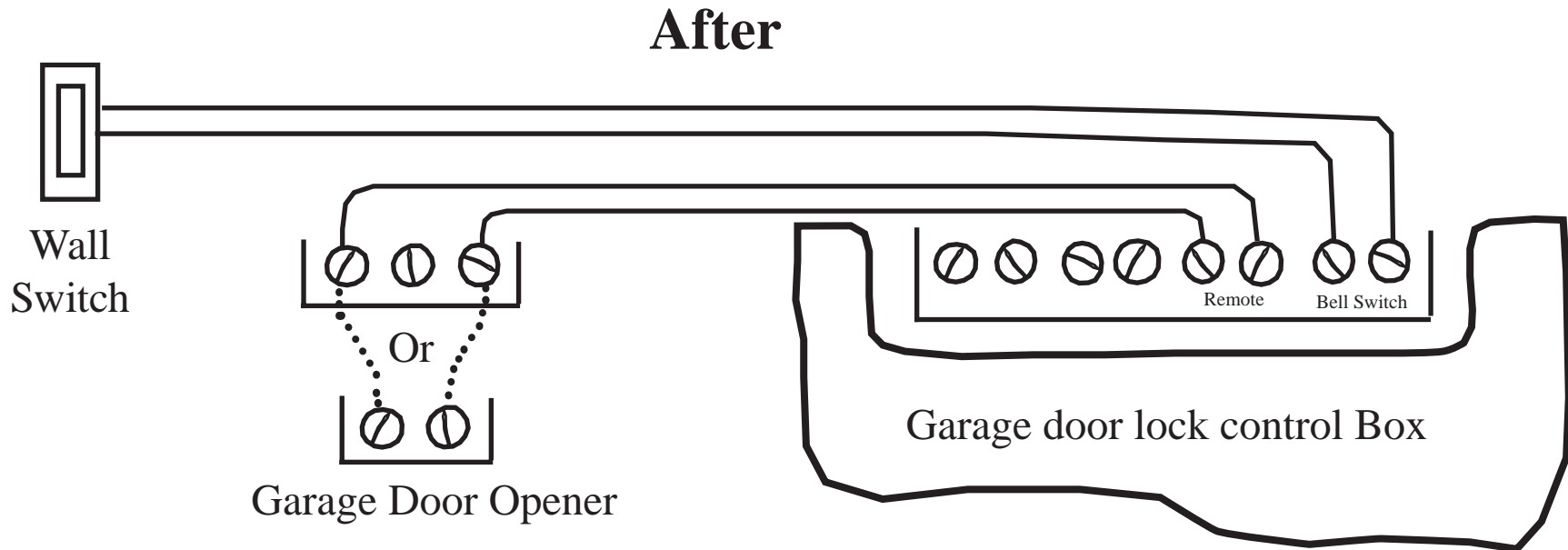
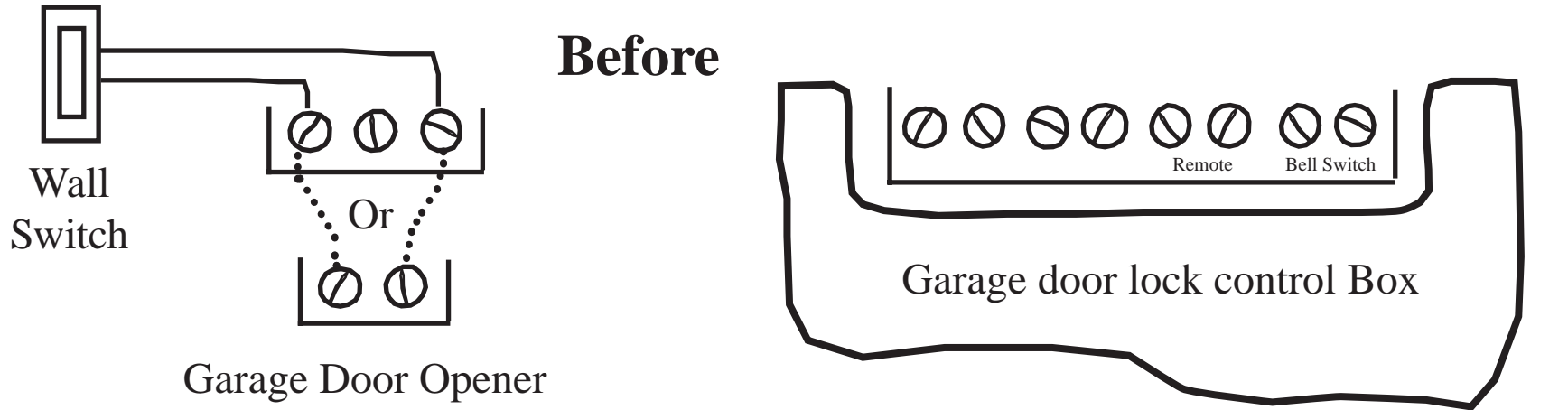

NOTE: THIS IS ONLY A GENERAL GUIDE, NOT ALL GARAGE DOOR TERMINALS ARE THE SAME.

Step 16

Mounting Magnetic Door Switch

Mount magnetic door switch to top left corner of door and header see **figure 9**.

Suggestion: Mark position of magnetic bracket with the door closed. Open door and install bracket in marked position. Close door and adjust as necessary. **Caution:** Do Not Crush Magnetic Switch Between Door and Header.

Step 17

Checking Clearances.

Move door fully open and fully closed MANUALLY checking all clearances for proper movement.

Figure 9 Checking alignment of magnetic switch assembly

Watch to make sure the door clears the magnetic switch mounted on the header. If any contact is made you must mount the magnetic switch higher until no contact is made. Re-adjust the magnet on the door to align with the magnetic switch.

CAUTION
Not correct



Operating
Clearance
Position

Check distance between the magnetic switch and the magnet mounted on the door, allowance is 3/8" to 1/2".

Check the alignment of the magnetic switch to the magnet. This alignment is important, the lock will fail to operate properly if magnet and switch are not correct.

Adjust bracket angle to align magnet and switch

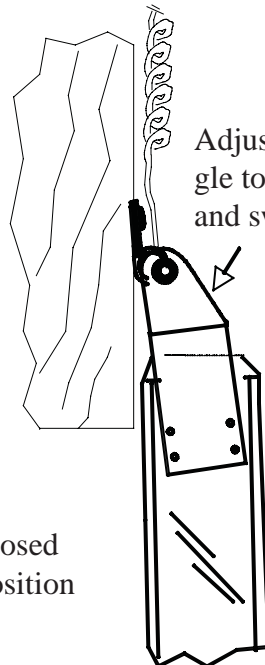

Closed
Position

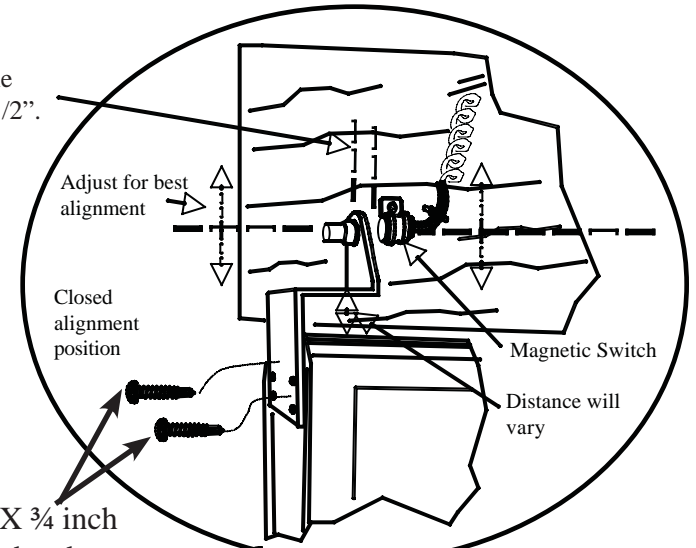

#8 X 3/4 inch
pan head-
Philips, self
drilling,
self tapping
screws

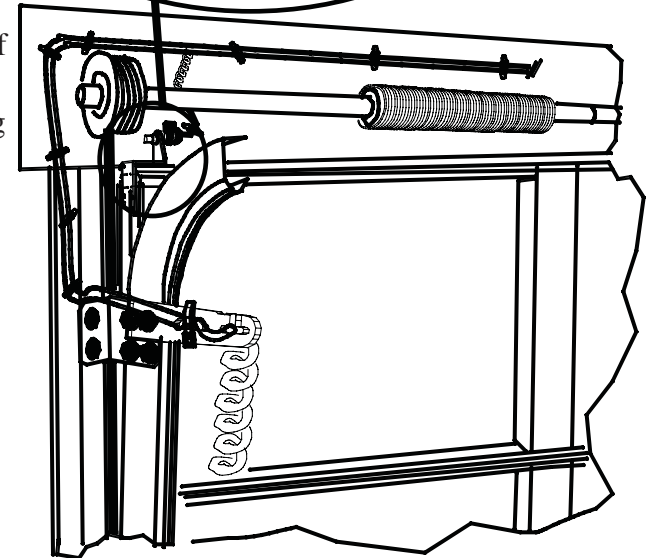

Installing Red L.E.D.

Locate pilot hole using measurements in **figure 10**. From inside of door, drill through door, with 1/8" pilot hole. From outside of door drill 5/16" hole using pilot hole reference. Insert LED from inside through hole. Hold LED mount firmly & insert LED into its own holder. To prevent rust, apply silicone to LED mount & insert complete assembly into hole. Wipe off excess silicone, See **figure 11**.

Figure 10 LED hole location

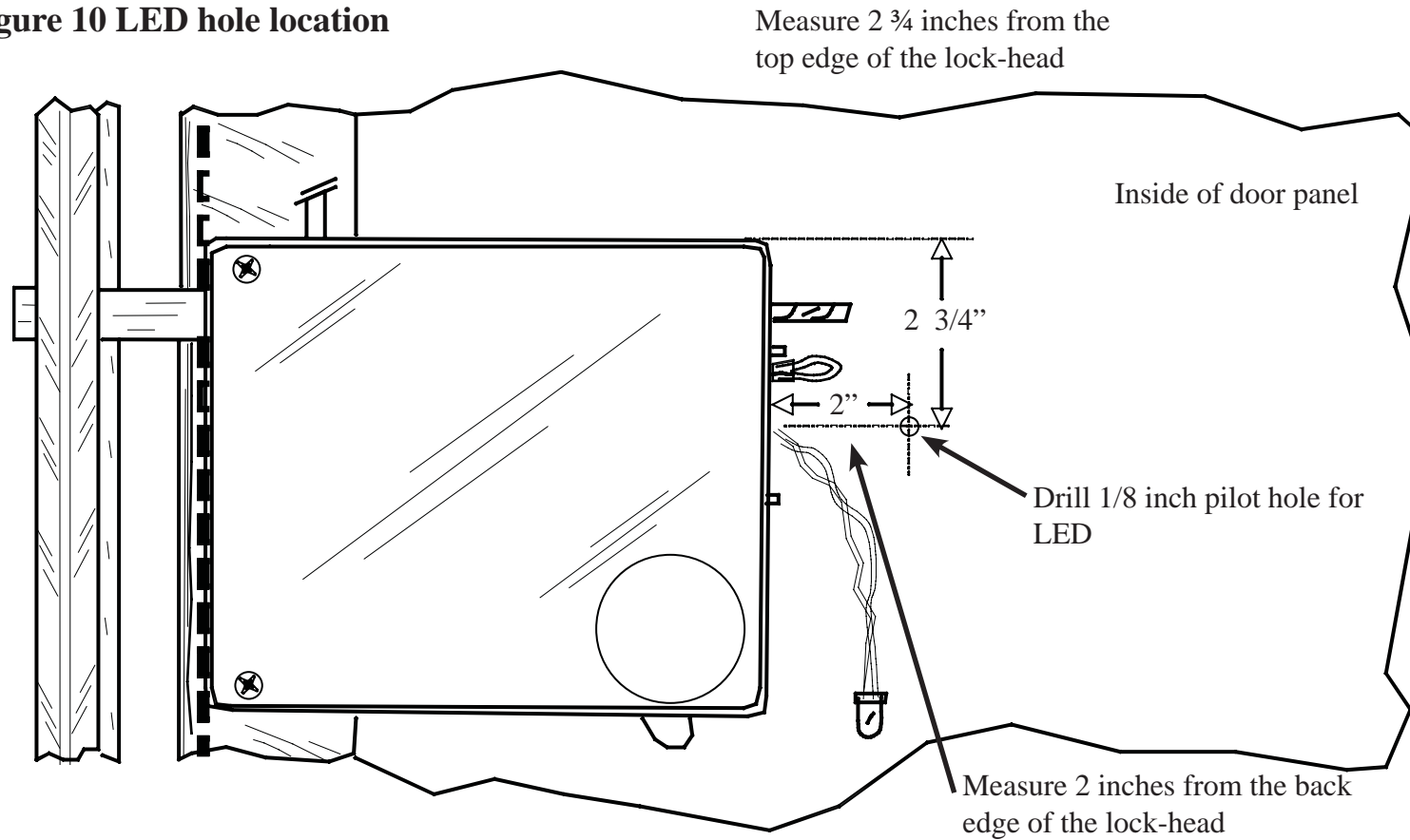

LED Install Through Door Panel

Figure 11

Step 19

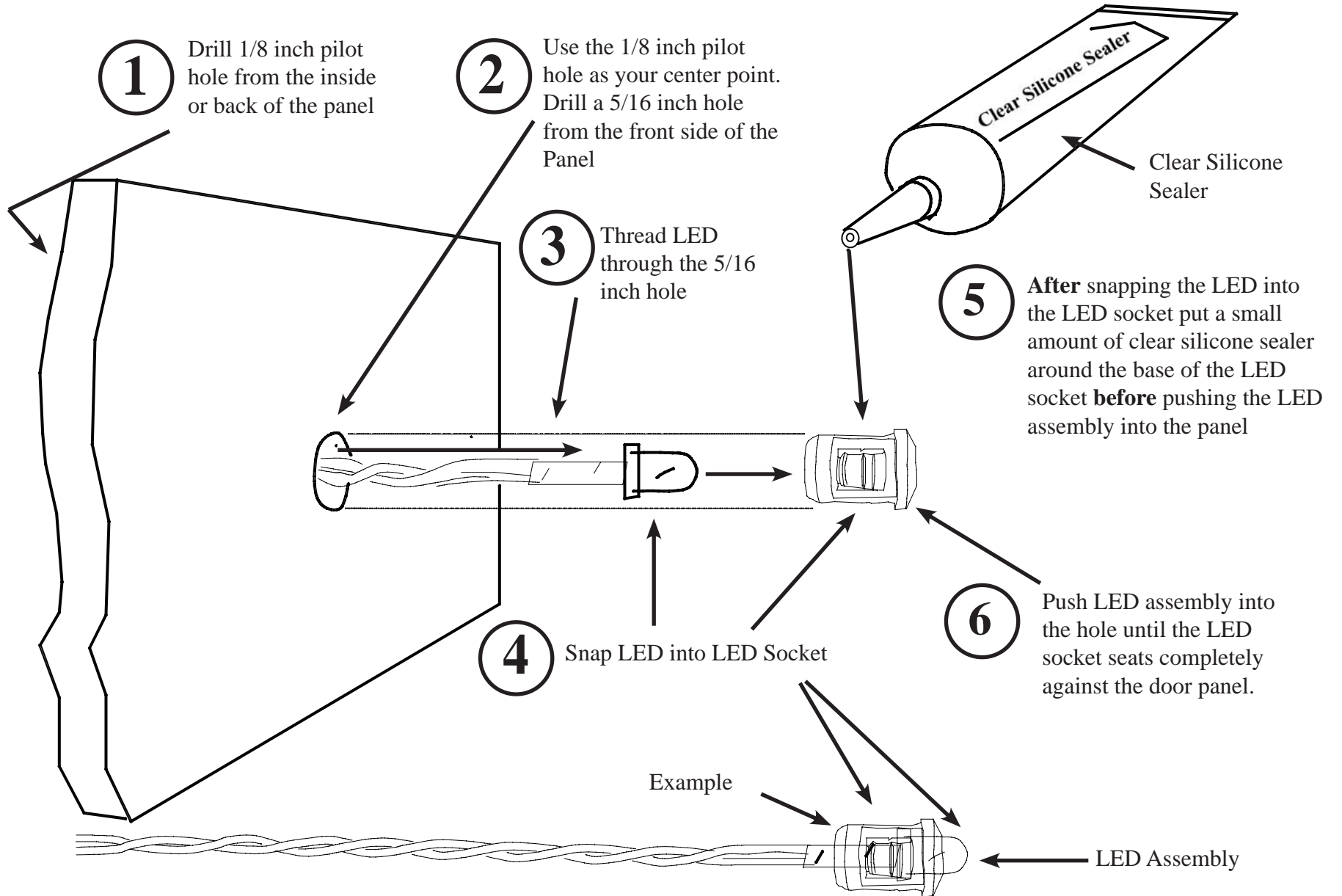

Powering Up

Plug operator into the garage door lock electrical control box and then plug in the garage door lock control box into 110V AC outlet.

Step 21

Learning Remotes.

Learn all remotes following procedures in Operating Instructions, (learning and unlearning remotes to control box).

Step 22

Latch Door to Rail.

Latch door back into operator. Release catch to reconnect door with operator. (Reconnect emergency release on operator.)

Step 23

Operational Check.

Operate door using remote or bell switch to check operation.

CAUTION

CAUTION

CAUTION

Caution: Never attempt to open door with any other remotes or keypads – other than the garage door lock remotes- supplied with lock kit or optional keypad.

This Section Is For One Piece Doors ONLY

For complete information on one piece door installation instructions it will be necessary to refer to **Steps** 1, 2, 3, 7, 11, 12, 13, 14, 15, 17, 18, 19, 20, 21, 22, and 23 of this instruction manual.

Note: One piece doors require a dual head lock Kit.

Use this section for mounting lock-head (A) and lock-head (B) on a one piece door, along with the metal wire bracket and the magnetic switch assembly.

NOTE: **After** mounting the spacer blocks as shown on page 27. Use the sheet Labeled “Use This Dimension” as a reference for lock-head location. Make marks on spacer block as shown in **figure 1** or the first section of this manual.



Make reference marks as previously stated, **after** spacer blocks are installed on the door, and **before** the lock-heads are installed on the spacer blocks.

How To Mount Lock-Head (A) and (B) On a One Piece Door.

Mount lock-head (A) and lock head (B) spacer blocks as shown in figures below.

Note: Spacer blocks must be mounted as close to the bottom of the door hinge as possible, you may need to adjust for best fit. Keep in mind the lock bolts need to clear any hardware, springs or door jam edges as they extend to their fully locked position.

Drill and counter-sink 3/16" relief hole for drywall screw to pass through spacer block. Now drill 5/64" pilot holes as shown below, to keep from splitting the wood.

Use dimension given on sheet titled **"Use This Dimension"** to correctly center the lock assembly and make reference marks on the spacer blocks.

Mount lock-head (A) using the reference mark as shown below.

Mount lock-head (B) using the reference mark as shown below. **CAUTION: Do not stretch wire cable, do not mount lock-heads past reference marks!!**

After installing lock-heads and attaching cable to door, pull manual release lever and check lock bolt clearance for binding, unwanted contact with springs, door jams and hardware.

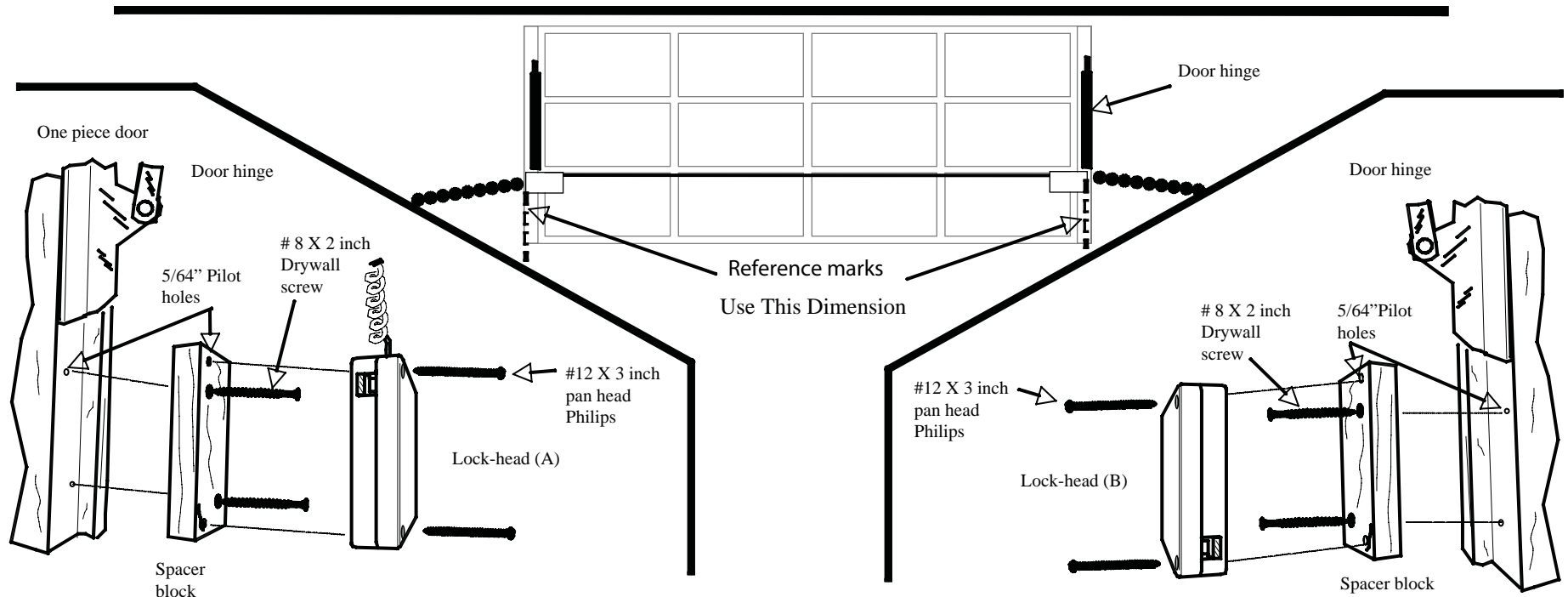

Metal Wire Harness Bracket For One Piece Doors

Place metal bracket on large pivot rod with the curved end toward the garage door, 5/8 of an inch away from the hinge plate see **figure (a)** below.

Tighten thumb screw and check to be sure the metal wire bracket is not rubbing on the hinge plate.

Use two plastic ties to fasten the wire harness to the metal wire bracket as shown below in **figure (b)**.

Note: Align the beginning of the first coil on the wire harness with the end of the metal wire bracket as shown below in **figure (b)**.

Route wire upward along wall leaving enough cable for door movement keeping wire clear of any moving hinges or door parts. Continue routing wire across header to hook as shown in step 11.

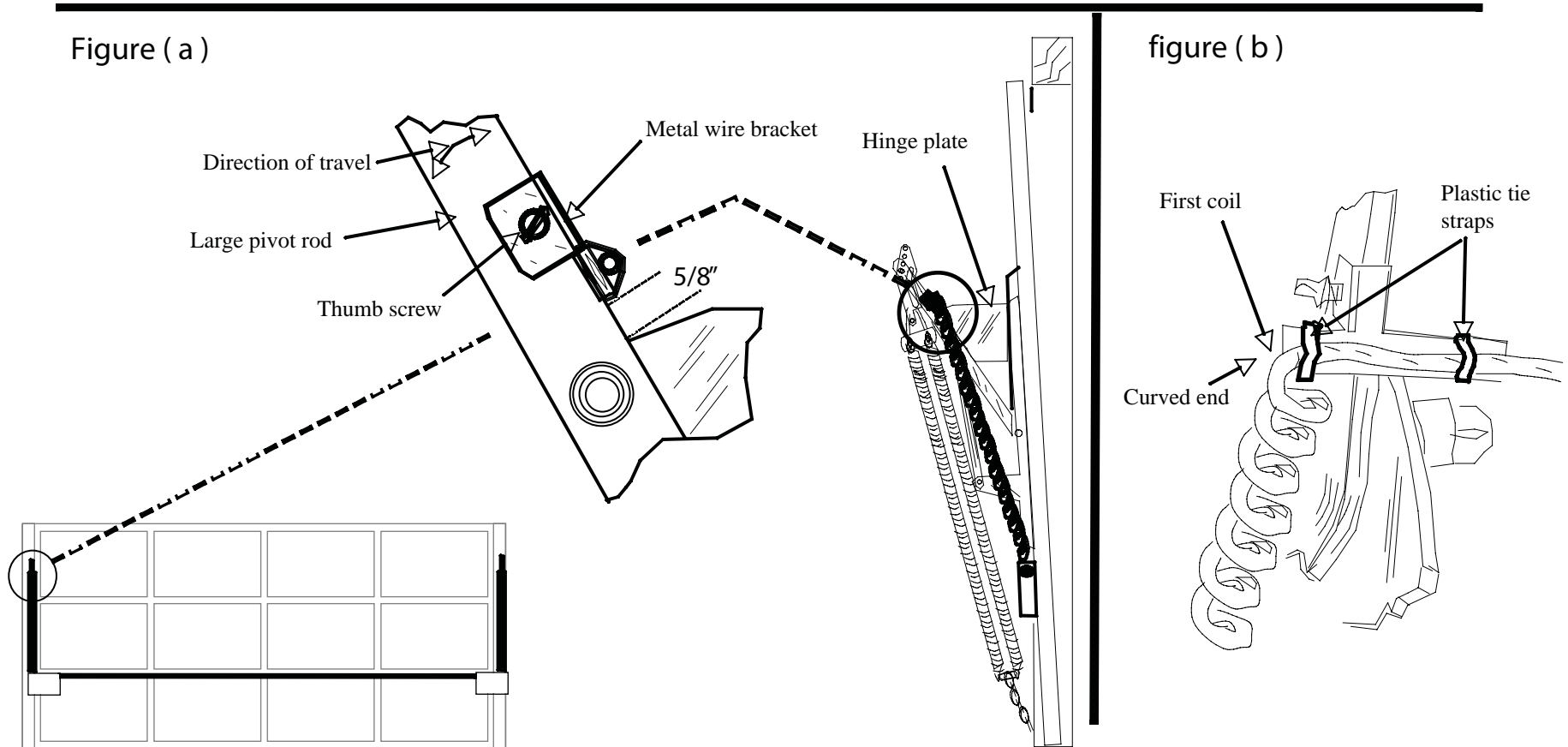

One Piece Door Magnetic Switch Installation

This instruction sheet is for **ONE PIECE DOORS ONLY**

Temporarily position the magnet and plastic bracket against the side edge of the door panel to help locate mounting point of magnetic switch to header.

Install magnetic switch on header as shown below **figure (A)**.

Align and install plastic bracket and magnet assembly as shown **figure (A) and (B)**.

You may need to do final adjustments on the switch assembly.

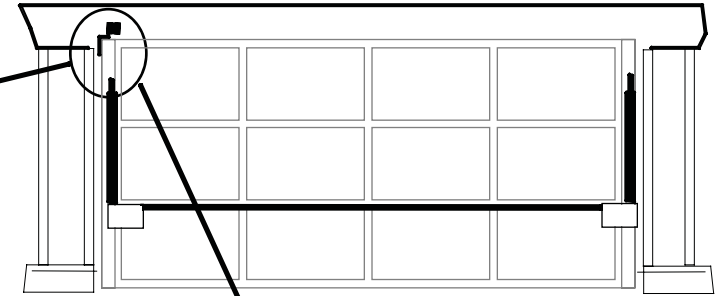

Figure (A)

Garage door header

Check distance between the magnetic switch and the magnet mounted on the door, allowance is 3/8" to 1/2"

Magnet and switch alignment

Magnet and plastic bracket assembly

#8 X 3/4 inch pan head-Philips, self drilling, self tapping screws

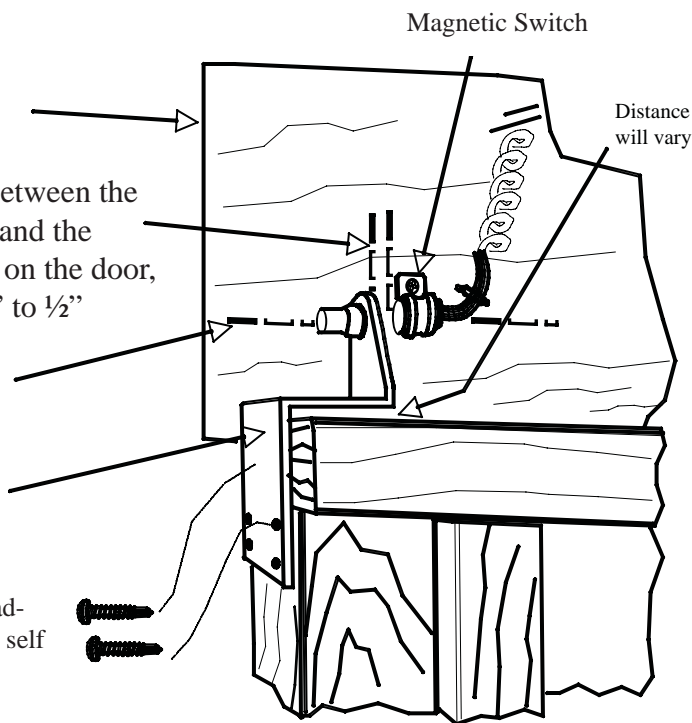
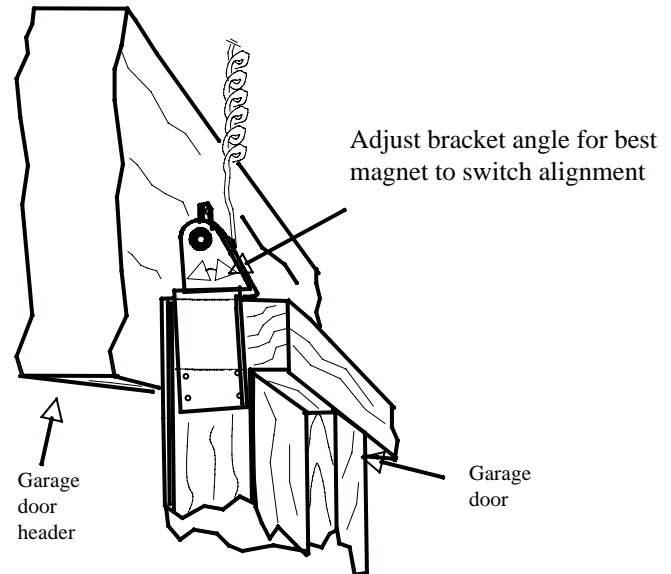

Figure (B)



Normal Operating Instructions

Learning and unlearning the remotes to the control box.

TO LEARN the remotes: Press and hold the learn button on the **garage door lock control box**. The red LED will light up and then go off. Release the learn button.

Now press the top left button on the remote **ONCE** then wait one second press it again, wait one more second press the button one more time. The light bulb on the control box should turn on. The learning process for that remote is now complete. As a test, press the top left button on the learned remote. The light bulb on the control box should respond by turning on or off as commanded. Repeat the entire learning procedure above to learn more remotes. **Note:** (Use 60 watt max. **incandescent** bulb only in the garage door lock control box)

TO UNLEARN the remotes: press and hold the learn button, LED turns on, hold until the red LED turns off, continue to hold the learn button until the red LED turns on again. Release the learn button while the red LED is on. All remotes and keypads are now unlearned.

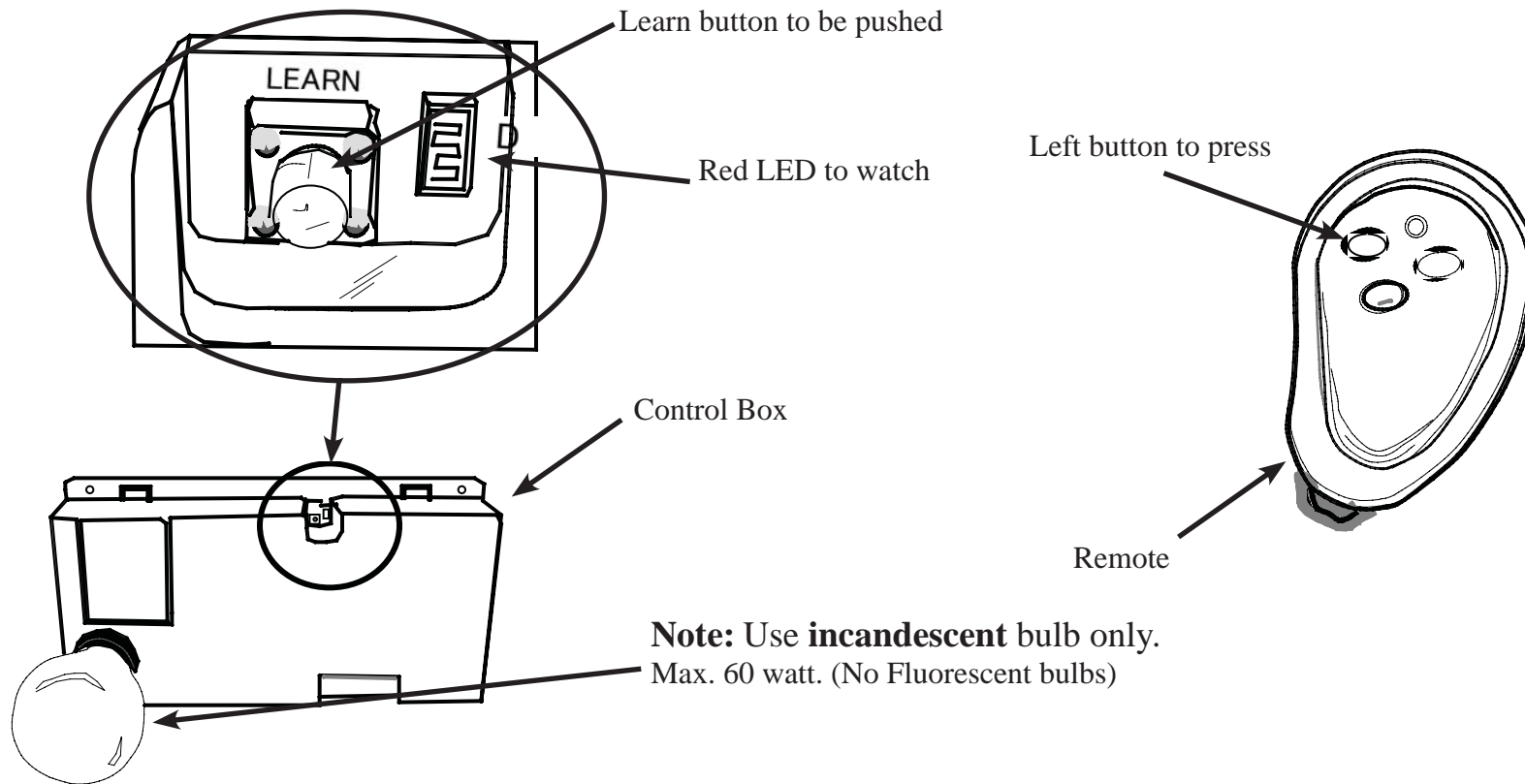

Activating and Deactivating the Auto-Close and Lock Feature

Activating the auto close feature is **NOT** recommended on doors & openers, **not** equipped with sensor beams, or pressure reverse systems!

Caution: This lock kit comes from the manufacturer with the auto close feature deactivated. If you choose to activate the auto close feature, take extra precautions when working in and around the garage door way. **DO NOT Leave anything in the door way that can block or stop the door from closing. (Vehicles, Toys, projects, Children, pets, etc.).**

Door will close Automatically after audio and visual warnings!!!

Note: All garages must have a wall switch installed to activate this feature.

How to Enable: Hold wall button pressed continuously, door may open or close while performing this operation, press **Special Function** button on remote 2 times with 1 second between each push, a beep will be heard with each press of the remote button. The first time setting is 20 min., each press of the remote button makes the door close sooner by 5 minutes. Example 20-15-10-5. Look for light bulb to flash TWICE. This indicates enable is complete.

How to Disable: Hold wall button pressed continuously, door may open or close while performing this operation, press **Special Function** button on remote 2 times with 1 second between each push. Look for light bulb to flash ONCE. This indicates disable is complete.

How to Disable Temporarily:

A: If the door is closed push wall button 2 times within 5 seconds the light bulb flashes ONCE. The garage door will open and stay open until the next full cycle.

B: If door is open push wall button 2 times within 5 seconds light bulb flashes ONCE. The door will start to close then stop. If door full open position is desired, button may be pushed once more within 5 seconds from initial push.

If door is stopped one foot or so from full closed position, for ventilation, auto close is still activated until wall button is pushed 2 times within 5 seconds.

If a beeping sound is heard with flashing light bulb, wall button or **Special Function** button on the remote can be pushed ONCE to temporarily stop auto close. One light bulb flash and beep will be seen and heard to confirm temporary disable.

If opening door normally from bell switch inside garage, a beep is heard to indicate auto close is activated, no beep heard means auto close is not activated.

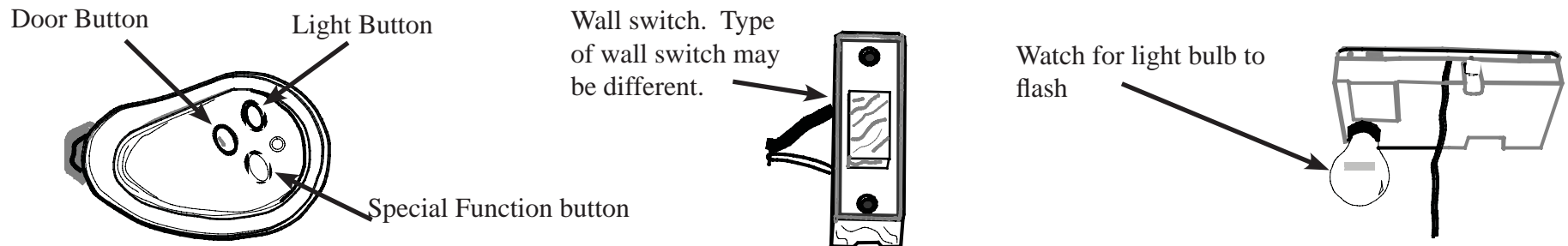

Power Failure - Manual Lock Operation

Manual Lock Operation

If the power goes out or if the garage door operator stops working you can still operate the garage door and GARAGE DOOR LOCK manually. **BEFORE** you pull the garage door release on the operator track, manually unlock the GARAGE DOOR LOCK, follow the instructions as shown below.

When the power is restored or comes back on, if the door is closed, the lock will automatically lock in 5 seconds.

Locked Position

To unlock, move the manual release handle in the direction of the arrow.

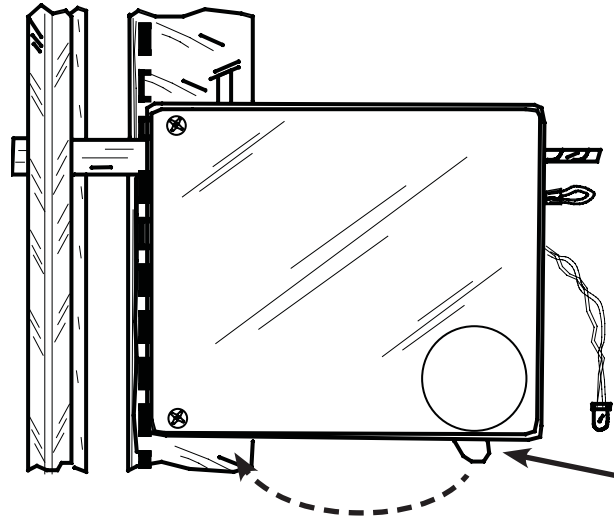

Unlocked Position

To lock, move the manual release handle in the direction of the arrow.

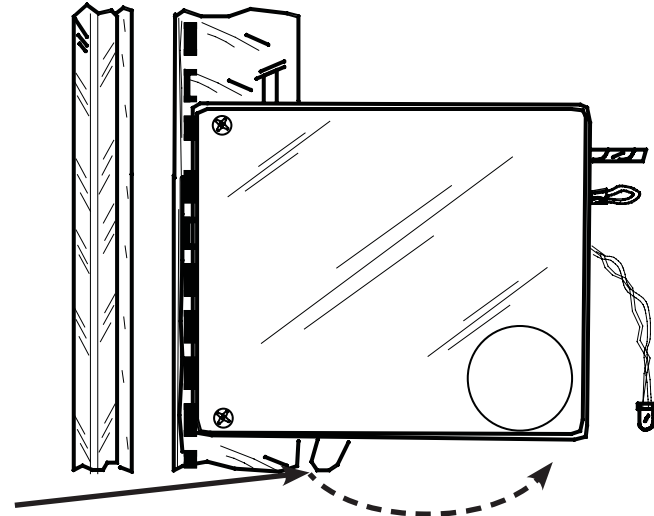

Manual Release Handle

For garage doors without operators.

Push the door button on the remote or on the wall, the lock unlocks and you can open the garage door manually.

Push the door button **JUST BEFORE** closing the garage door, manually close the door and the lock automatically locks.

Replacement Parts and Accessories



Manual Key Pull Kit

Used for manual emergency release. From the outside of the garage.
Required on single entry garages.



Wireless Keypad

Convenient keyless entry.



Extra Remote

Replacement Parts

Remote Battery

Replace with a 12V Type 23A battery.

Light Bulb

Replace with a standard 40 to 60 watt 110 VAC incandescent light bulb only. **CAUTION: TO AVOID POTENTIAL FIRE HAZARD, LIGHT BULB MUST NOT EXCEED 60 WATTS at 110 VAC.**

How to Change Batteries

To Change the battery in the remotes follow steps A-F as shown below in figures 12 and 13.

- (A) Use a jewelers phillips screwdriver to remove the screw holding the remote assembly together.
- (B) Gently separate the remote case halves. Caution: The LED may need to be gently pushed back out of the top face cover.
- (C) While pulling the assembly apart, keep the circuit board and button set in tact as best you can.
- (D) Replace the battery with the positive (+) terminal, to the positive (+) terminal on the circuit board as shown in figure (a) below.
- (E) Reassemble the circuit board with the new battery into the bottom case half of the remote. Take care to align the circuit board with the guide tabs.
- (F) Position the button set onto the circuit board buttons. Place the top face cover on the assembly and guide the LED back through the LED hole. Make sure the button set aligns in the button holes. The top face cover and the bottom half will snap together. Reinstall the screw and tighten. See figures (a) and (b).

Figure 12

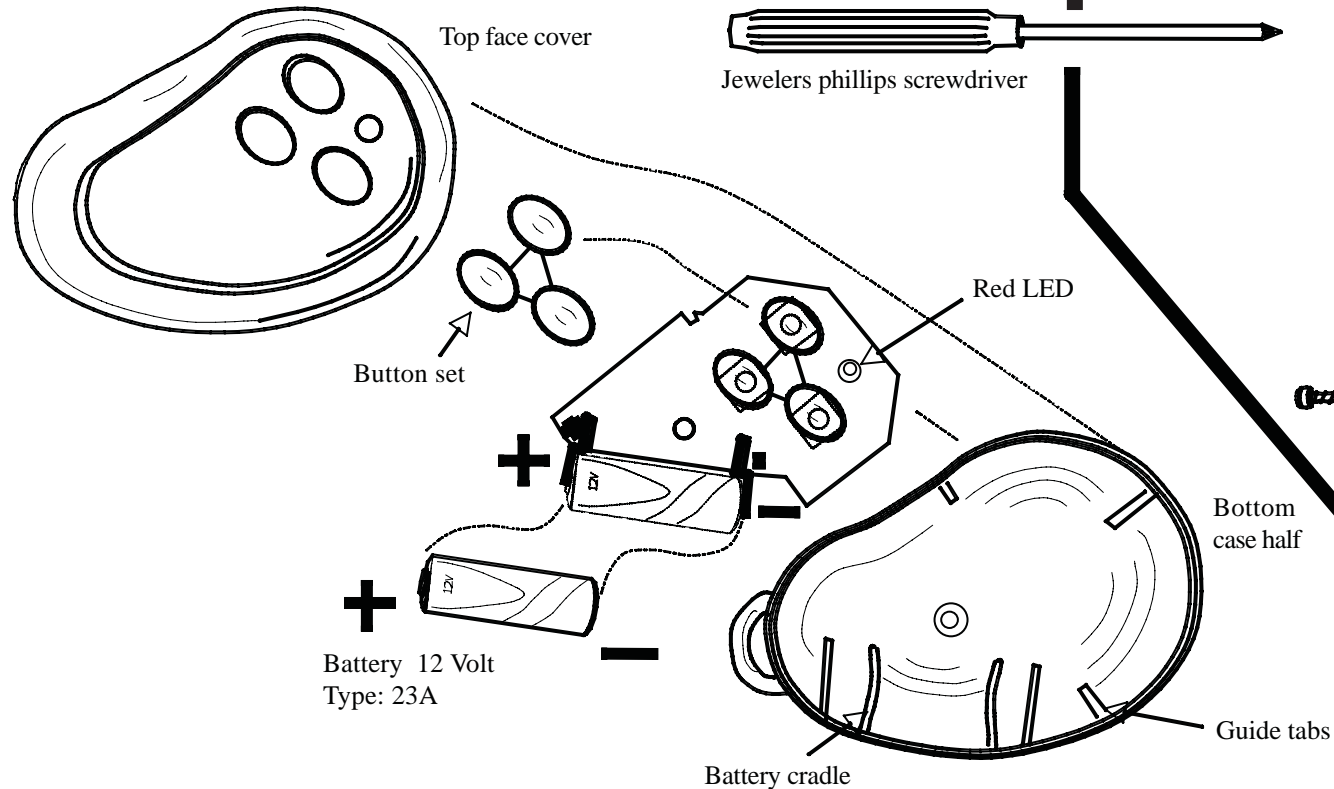
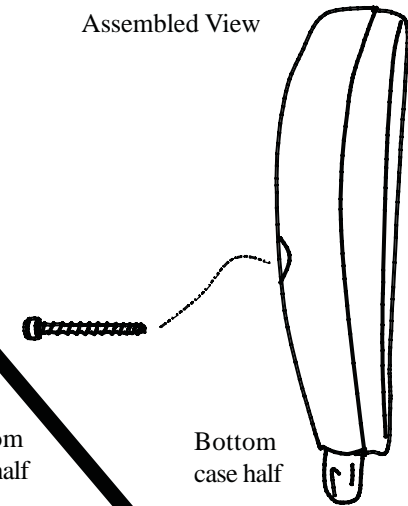

Figure 13



Warranty Limitations and Guidelines

We at Elocksys limit warranty of this product as stated below.

One year limited warranty on mechanical and electrical components only, against manufacturers workmanship and material defects.

We test each lock before it is packaged for sale, we will not cover or be responsible for damage as a result of mishandling, pure or incorrect installation, nor will we cover human error or implied accidents by the customer or installer.

We provide a battery with each remote in the kit, it will be the customers responsibility to replace the battery should it lose power. The customer is responsible for replacing the light bulb, even though one may be provided in the kit.

The customer must pay the shipping and handling for the replacement unit and for the return of the alleged defective unit to the factory. The customer will be billed for the replacement lock until the lock returned for warranty is evaluated.

Each warranty claim will be processed on an individual case by case basis.

WE MAKE NO OTHER WARRANTY, EXPRESS OR IMPLIED, AND WE DISCLAIM ANY WARRANTY OR ANY OTHER KIND, INCLUDING ANY WARRANTY OF MERCHANTABILITY OR FITNESS FOR A PARTICULAR PURPOSE.

WE AND YOU AGREE THAT THE SOLE AND EXCLUSIVE REMEDY FOR NONCONFORMING GOODS SHALL BE REPLACEMENT OF DEFECTIVE GOODS. The parties acknowledge that the price of our products would be much greater if we undertook more extensive liability.

This warranty shall not apply to damage resulting from (I) loss or damage in transit, (II) unreasonable use, (III) Buyer's negligence, or (IV) accident. We reserve the right to examine the alleged defective goods to determine whether the warranty is applicable.

Please register and notify Elocksys of the purchase and installation of your new lock assembly. Fill out the warranty card completely or register on line at our web site. The information you provide on the registration card is to be used for individual customer relations and Warranty confirmation purposes only. Your privacy is important to us, the information on the warranty registration card will not be sold or shared.

The information on the survey card is optional and voluntary and may be sold or shared for marketing and survey purposes.

The one year warranty starts with, date of sale or purchase to the end user, not date of installation and is limited to the original purchaser. These requirements include the purchases from wholesale distributors, stores, contractors and retailers.

You must Show proof of purchase, date and location of installation upon warranty request, which will be matched with the product registration. The warranty will be void if false information is provided on the registration document or proof of purchase receipt by the original purchaser.

Some states do not allow specific or general limitations on product warranty, Implied or incidental. However the legal protections provided by the state in which the purchaser, user resides will be observed.

Elocksys reserves the right to repair or replace lock assemblies and individual parts with tested and known good reclaimed parts or new parts.

Repairs of lock assemblies and parts that exceed the ONE YEAR LIMITED WARRANTY period, will be paid by the customer, at current labor and part rates, along with shipping and handling.

For warranty service contact elocksys at: 760-479-1413 www.elocksys.com

Troubleshooting

For technical assistance, contact us at www.elocksys.com

The **garagedoor lock** is assembly tested, unit tested and run tested for quality assurance before it is packaged for sale. We at Elocksys Inc. take pride in creating products that customers can rely on.

Use this troubleshooting table to help troubleshoot possible errors that may occur during installation or everyday use of the **garagedoor lock**.

This troubleshooting table is designed to help quickly identify the source of most malfunctions that may occur with the **garagedoor lock**. Refer to the garage door and door operator owners manuals for malfunctions not related to the lock.

If necessary to service or test garage door or opener be sure to manually unlock and disable the garage door lock.

How to use this troubleshooting table.

Go to the Item section in question:

REMOTES

LOCK CONTROL BOX INCLUDING LIGHT BULB

LOCK HEAD

OPERATOR (garage door operator)

This troubleshooting guide is a basic guide to help troubleshoot and identify the most common installation errors and possible malfunctions that may occur. For more complex issues contact and authorized service technician.

Troubleshooting Remotes

Symptom	Problem	Possible Solution
No response when Light or Door buttons is pressed and held for at least 1 second.	LED blinks rapidly or does not light	Check battery contacts and/or replace battery.
	LED lights continuously when button pressed	Perform 'LEARN' function for the remote.
	Remote will not LEARN with a fresh battery.	Contact authorized service technician.
	LED does not light with fresh battery	Contact authorized service technician.

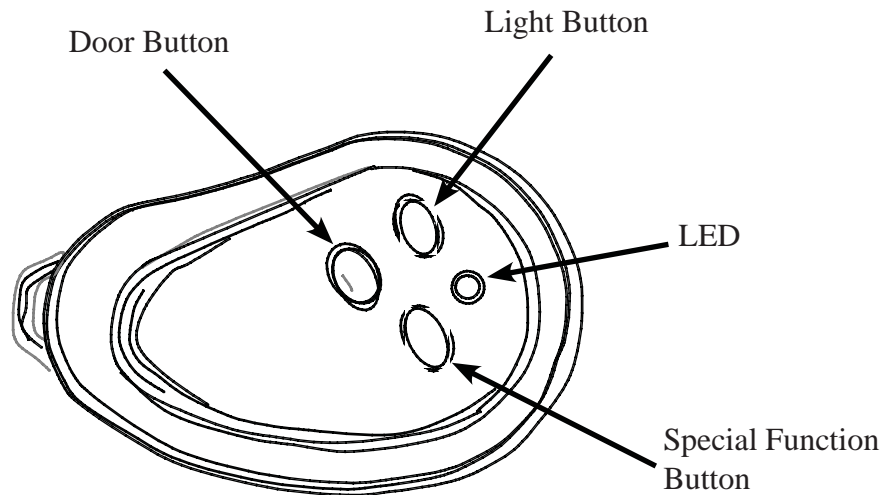

Troubleshooting Lock Control Box

Symptom	Problem	Possible Solution
LED does not light when 'LEARN' button is pressed on control box.	Control box not plugged into the 110V AC outlet.	Plug control box into the outlet.
	Outlet has no power.	Make sure switches and circuit breakers are turned on for the outlet.
	Circuit breaker on the Lock Control Box is tripping.	Contact authorized service representative.
	House circuit breaker tripping.	Contact qualified electrician.
Light on Control Box does not turn on.	Light bulb burned out.	Replace with new bulb. Caution: Bulb must not exceed 60Watt incandescent only.
	Known good bulb still does not turn on.	Contact authorized service representative.

Troubleshooting Lock Head

Symptom	Problem	Possible Solution
Lock does not unlock when either the bell switch or remote is pressed.	Control box not plugged into the 110V AC outlet.	Plug in Lock Control Box.
	Control box plugged in, not working.	Go to the section on troubleshooting the Lock Control Box.
Lock runs, but does not unlock fully.	Lock bolt is rubbing on sides of receiver hole.	Enlarge the receiver hole.
	Debris or binding in the lock mechanism.	Contact authorized service representative.
Lock runs, unlocks fully, motor continues to run and door does not open.	Faulty limit switch in lock mechanism.	Contact authorized service representative.
When door closes, lock does not lock.	Faulty alignment of magnetic switch and magnet, or distance between magnet and switch.	Check alignment of magnetic switch and the magnet mounted on the door.
	Magnet and switch align, problem is in wiring or control box.	Contact authorized service representative.
Lock runs, but does not lock fully, red LED does not light.	Lock bolt is rubbing on sides of receiver hole. Receiving hole is obstructed.	Enlarge or clean the receiver hole.
	Debris or binding in the lock mechanism.	Contact authorized service representative.
Lock runs, locks fully, motor continues to run for a while and red LED does not light.	Faulty limit switch in lock mechanism.	Contact authorized service representative.

Troubleshooting Garage Door Operator Opening

Symptom	Problem	Possible Solution
Lock unlocks correctly, the door does not open.	Lock not fully unlocked.	See the section on Troubleshooting Lock Head.
	Garage Door Operator not plugged in to the 110V AC outlet.	Plug the door operator into the outlet on the Control Box.
	Loose bell wire from Control Box to operator.	Reconnect bell wire.
	Door operator not working or Lock Control not generating signal to the operator.	<ol style="list-style-type: none"> 1. Unplug lock from 110V AC outlet. 2. Manually unlock the door. 3. Plug opener into 110V AC outlet. 4. Wire bell switch on the wall to the opener. 5. Press the bell switch. 6. If the door opens, contact your authorized garageDoor lock service representative. 7. If the door does not open, contact your service representative for your opener.

Troubleshooting Garage Door Operator Closing

Symptom	Problem	Possible Solution
When the door is open, the door does not move at all when either the bell switch is pressed or the remote is used.	Garage Door Operator not plugged in to the 110V AC outlet.	Plug the door operator into the outlet on the Control Box.
	Loose bell wire from Control Box to operator.	Reconnect bell wire.
	Door operator not working or Lock Control not generating signal to the operator.	<ol style="list-style-type: none"> 1. Unplug lock from 110V AC outlet. 2. Manually unlock the door. 3. Plug opener into 110V AC outlet. 4. Wire bell switch on the wall to the opener. 5. Press the bell switch. 6. If the door opens, contact your authorized garageDoor lock service representative. 7. If the door does not open, contact your service representative for your opener.
When the door is open, the door starts to move when the bell switch or remote is pressed, but the door stops or reverses direction.	Safety beam in door is interrupted.	Make sure sensors are aligned and nothing is blocking the beam.
	Mechanical binding of the opener drive or door track.	Check the troubleshooting section of your opener manual.

Page 43

Lock installation on garage doors with “**Wayne Dalton**” openers with wireless indoor controller. These steps must be followed carefully!

Step 1

Before starting lock installation make sure the door is balanced and operator works as specified by manufacturer including all adjustments and pressure settings.

Step 2

Unlearn all remotes, keypads, & indoor controls, after all adjustments are completed as specified by manufacturer. See page 35 of this manual for unlearn procedures.

NOTE; Setting the door stopping points and reverse pressure are done using the indoor wireless controller, make sure this is completed before unlearning the wall control unit. At this time remove wall mounted control unit, keypads, collect all remotes. Place items in RED bag supplied with this kit.

Step 3

Unplug opener at this time.

Step 4

Install lock assembly as instructed in the garage door lock instruction booklet, the only exception is where to mount the garage door lock control box. Control box must be mounted where the Wayne Dalton opener plugs into the 110vac outlet. Care must be taken when routing wire to keep clear of all moving parts.

Step 5

Locate bell switch terminals. On the “Door Master” model, under plastic cover in light bulb compartment, in right side end cover of motor drive on “Extension Spring” or “Torquemaster” models, or behind gear on the right side of “Torsion Spring” models.

On models with terminal blocks numbered 1, 2, 3, always use terminals 1 and 3. On others that have two terminals just use terminals. These terminals need to be exposed to connect the garage door lock control box. See page 18 for general connection instruction.

Step 6

Mount new wall switch (not included in kit) where wireless controller was mounted on wall, or mount in a location at least five feet from the floor to keep out of reach from small children. Run bell wire from switch to terminals on the garage door lock control box labeled bell switch. NOTE: this switch is also used to activate and deactivate autoclose feature.

Step 7

Now wire in two wires from Wayne Dalton terminals, covered in step 5, to terminals labeled remote terminals of garage door lock control box.

Caution:

Indoor wall mounted control assembly must be kept in a safe place and **NOT** discarded! In the event the opener needs service, this controller must be used by the service technician. Caution: In order to service any garage door opener, the garage door lock must be manually unlocked and disabled. The following steps must be taken **before** relearning this controller to the Wayne Dalton opener.

First - Manually unlock the garage door lock then unplug the garage door lock control box from the wall outlet. Now the opener can be plugged directly into the wall outlet.

Second - Relearn wall control unit to the opener following the Wayne Dalton instruction manual.

Third - After servicing is complete, the Wayne Dalton wall control unit must be unlearned following the instructions on page 35 of this manual **BEFORE** reactivating the garage door lock.